

### FEATURES

- Size: 60 x 90 x 79 mm (4.5 DIN rail units).
- KNX System Power Supply with additional 29VDC output.
- 110VAC 50/60Hz input voltage.
- ZPS320MPA110 power supply generates and monitors the KNX system voltage supply.
- Maximum current 320mA (KNX bus plus additional output consumption).
- KNX coil included.
- DIN rail mounting (EN 50022), though pressure.
- Short-circuit and overload protection.
- Reset button and overload status LED.
- Conformity with the CE directives (CE-mark on the right side).

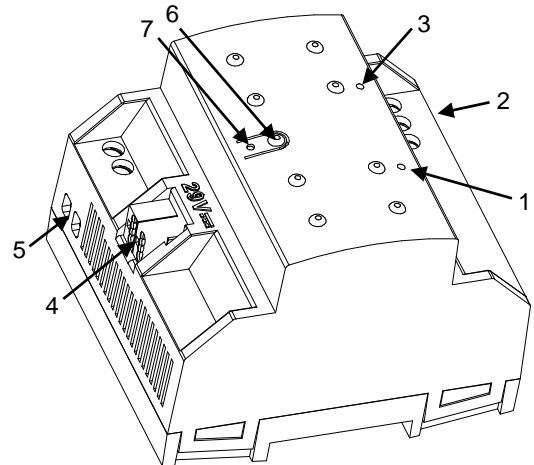

Figure 1: ZPS320MPA110 power supply

1. OVERLOAD LED	2. Main Power	3. POWER LED	4. KNX bus
5. Additional Output	6. RESET button	7. RESET LED	

	Safety isolating transformer, short-circuit proof
	For indoor use only

### Installation and connection.

- This KNX power supply must be exclusively installed in a 35mm DIN rail inside a distribution box or an electrical panel.
- Ensure adequate ventilation to prevent the range of the permissible temperatures from being exceeded.
- Main power must be connected to L, N and ground terminals, in accordance with the schematic represented in figure 2.
- The coil integrated bus output must be connected through a standard KNX connector.
- The additional output connection must be connected according to the polarity indicated on the enclosure.

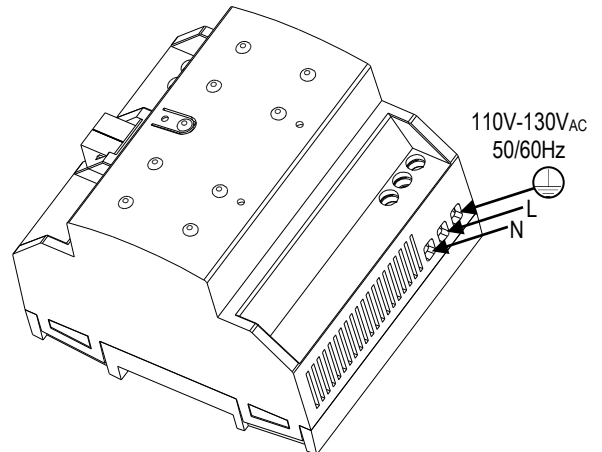

Figure 2: ZPS320MPA110 installation and connection

### Controls and indicators.

POWER LED indicates the status of the device :

- LED ON (green): the device is working properly.
- LED OFF: input voltage failure.
- LED blinking (green): KNX bus and/or additional output short-circuit.

OVERLOAD LED indicates if the maximum current specified is exceeded:

- LED OFF: maximum current specified is not exceeded.
- LED blinking (red): switch off due to overload in the KNX bus and/or the additional output\*.
- LED ON (red): bus and/or additional output line overload\*.

\*Reduce the load on the bus and/or the additional output lines until its total consumption does not exceed the maximum current specified. After that, please reset the bus power supply.

**Note:** To reset the bus power supply, the RESET button should be pressed (it is recommended to hold it for at least 5 seconds to verify the reset of all the devices in the line). The RESET LED will blink slightly in RED while the RESET button is pressed.

GENERAL SYSTEM SPECIFICATIONS		
CONCEPT		DESCRIPTION
Type of device		Electric Operating Control Device
External power supply	Voltage	110V-130VAC 50/60Hz
	Consumption	Max. 300mA
Bus output	Voltage	29VDC SELV (KNX coil included)
	Output (I <sub>BUS</sub> )	Max. 320mA
Additional output	Voltage	29VDC SELV
	Output (I <sub>AUX</sub> )	I <sub>AUX</sub> + I <sub>BUS</sub> ≤ 320mA
Operation temperature		from -5°C to +45°C
Storage temperature		from -20°C to +55°C
Operation humidity		from 30 to 85% RH (no condensation)
Storage humidity		from 30 to 85% RH (no condensation)
Complementary characteristics		Class B
Protection class		Class I
Operation type		Continuous operation
Device action type		Type 1
Electrical stress period		Long
Degree of protection		IP20. Clean environment
Installation		Independent device to be mounted inside distribution boxes or electrical panels.
Minimum clearances		Not required
Power failure back-up time		130ms
Max current before overload		600mA
Protection fuse	Voltage	250V
	Current	2.5A
	Response	Type F (fast response)
Connection type		Screw terminal block
Cable section		from 0,5mm <sup>2</sup> to 4mm <sup>2</sup>
Operation indicator		Green POWER LED ON implies a correct bus voltage. Red OVERLOAD LED ON implies maximum output current exceeded.
Weight		284g
PCB CTI index		175V
Housing material		PC+ABS FR V0 halogen free

### Attaching Power Supply to DIN rail:

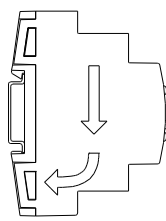
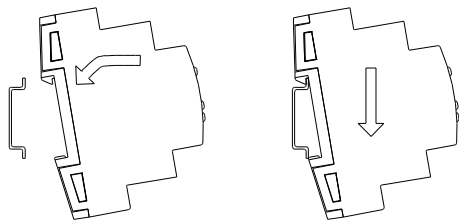

### Removing Power Supply from DIN rail:

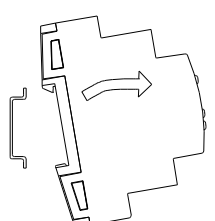
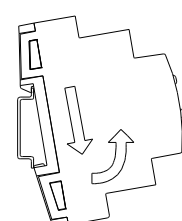
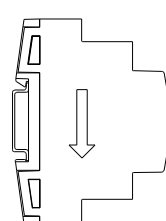

### SAFETY INSTRUCTIONS

- Installation should only be performed by qualified professionals according to the laws and regulations applicable in each country.
- Do not connect the mains voltage nor any other external voltage to any point of the KNX bus; it would represent a risk for the entire KNX system. The facility must have enough insulation between the mains (or auxiliary) voltage and the KNX bus or the wires of other accessories, in case of being installed.
- The facility must be equipped with a device that ensures the omnipolar sectioning. Installation of a 10A mini-circuit-breaker is recommended. To prevent accidents, it must remain open in case of manipulation of the device.
- The device has a short-circuit protection fuse that, in case of activation, should only be rearmed or replaced by the Zennio technical service.
- Once the device is installed (in the panel or box), it must not be accessible from outside.
- Keep the device away from water and do not cover it with clothes, paper or any other material while in use.
- The WEEE logo means that this device contains electronic parts and it must be properly disposed of by following the instructions at <http://zennio.com/weee-regulation>.

