

KLIC-SG vT

KNX – F3/F4 Gateway for Indoor Samsung A/C Units

ZCLSGVT

Application program version: [1.1]

User manual edition: [1.1]_a

www.zennio.com

CONTENTS

Contents	2
1 Introduction	3
1.1 KLIC-SG vT	3
1.2 Installation	4
1.3 Start-Up and Power Loss	5
2 Configuration	6
2.1 General	6
2.2 A/C Gateway	9
2.2.1 Configuration	9
2.2.2 Fan	19
2.2.3 Initial Configuration	23
2.2.4 Scenes	25
2.2.5 Error Handling	26
2.3 Inputs	29
2.3.1 Binary Input	29
2.3.2 Temperature Probe	29
2.3.3 Motion Detector	29
2.4 Logic Functions	30
ANNEX I. Communication Objects	31

1 INTRODUCTION

1.1 KLIC-SG vT

KLIC-SG vT from Zennio is a gateway that enables **full-duplex** communication between the KNX home automation system and **indoor range Samsung air-conditioning systems** through the 2-wire connection provided by the latter.

Because of this **bidirectional** communication, the air conditioning system can be controlled from the home automation system in the same manner as it is through its own controls. Moreover, the actual status of the unit can be monitored and periodically sent to the KNX bus to inform other devices.

The most outstanding features of KLIC-SG vT are:

- **Bidirectional control** of indoor Samsung A/C units (IDU) through the connection wires provided F3/F4.
- Control of the **main functions** of indoor Samsung A/C unit: On/Off, temperature, mode of operation, fan speed, etc.
- **Error management** to handle specific error codes from the A/C unit itself as well as any communication issues that may arise.
- **2 analogue-digital inputs**, for the connection of temperature probes, motion detectors or binary pushbuttons or switches.
- **10** customisable, multi-operation **logic functions**.
- Up to **five scenes**.
- **Heartbeat** or periodic “still-alive” notification.

1.2 INSTALLATION

1. Prog./Test LED
2. Prog./Test button
3. 2-wire communication connection with A/C unit (F3/F4 port).
4. Inputs Connector.
5. KNX Connector.

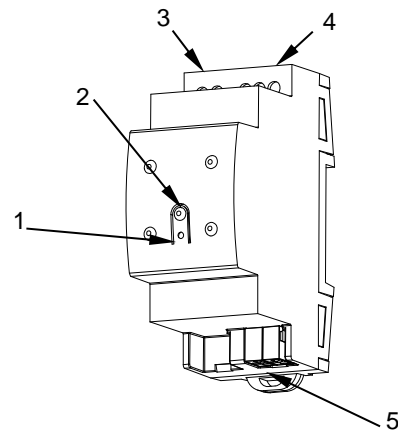

Figure 1. Element scheme.

KLIC-SG vT connects to the KNX bus via the corresponding built-in terminal (5). Once the device is provided with power from the KNX bus, both the physical address and the KLIC-SG vT application program can be downloaded.

This device does not need any external power as it is entirely powered through the KNX bus.

The remaining elements are described next.

- **Prog./Test button (2):** a short press on this button will set the device into the programming mode, making the associated LED (1) light in red.

Note: if this button is held while plugging the device into the KNX bus, the device will enter into safe mode. The LED will blink in red every 0.5 seconds

- **Analogue-Digital Inputs (4):** input ports for the stripped cables of external elements such as switches, motion detectors, temperature probes, etc.
- **F3/F4 Communication (3):** 2-wire communication cable that will connect KLIC-SG vT to the A/C unit. The other end of the cable, therefore, is intended to be connected to the F3/F4 connector in the PCB board of the internal unit.

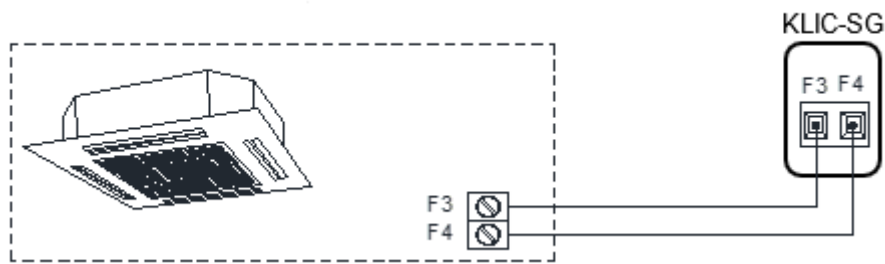

Figure 2. Connecting KLIC-SG vT to the F3/F4 bus.

Important: *KLIC-SG vT is not compatible with Samsung wired remote control.*

For detailed information about the technical features of KLIC-SG vT, as well as on security and installation procedures, please refer to the device **Datasheet**, bundled in the device packaging and also available at www.zennio.com.

1.3 START-UP AND POWER LOSS

Depending on the configuration, some specific actions will be performed during the device start-up. The integrator may set up an initial status to be sent to the A/C unit after the bus power restored, as well as the sending of certain objects to the KNX bus, as described in later sections.

On the other hand, when a bus power failure takes place, the device will interrupt any pending actions, and will save its state so it can be recovered once the power supply is restored.

2 CONFIGURATION

2.1 GENERAL

The general configuration of the device consists in enabling the specific functionalities that will be required during normal operation:

- **Heartbeat** or periodic “still-alive” notification.
- **Inputs**.
- **Logic functions**.
- **A/C gateway**.

The latter entails all functions specific to KLIC-SG vT, i.e., all the functions related to interfacing with the A/C unit and to the management of the climate control system.

ETS PARAMETRISATION

After importing the corresponding database in ETS and adding the device into the topology of the desired project, the configuration process begins by entering the Parameters tab of the device.

The General screen is shown in the first place, containing the following parameters:

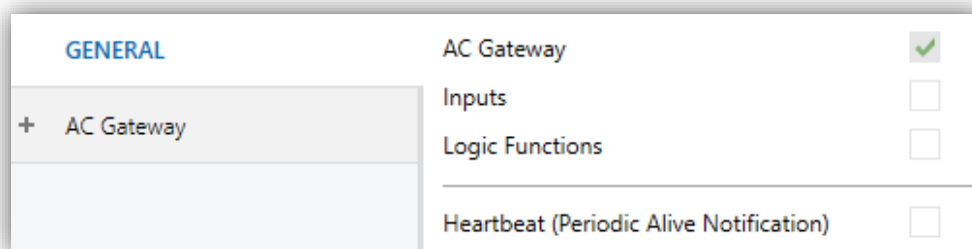

GENERAL	
+ AC Gateway	<input checked="" type="checkbox"/>
Inputs	<input type="checkbox"/>
Logic Functions	<input type="checkbox"/>
Heartbeat (Periodic Alive Notification)	<input type="checkbox"/>

Figure 3. General.

- **A/C Gateway** [[enabled](#)]¹: enables the “A/C Gateway” tab in the tree on the left. For more information, see section 2.2.
- **Inputs** [[disabled/enabled](#)]: enables or disables the “Inputs” tab in the tree on the left, depending on whether the device will or will not be connected any external accessories. For more information, see section 2.3.
- **Logic Functions** [[disabled/enabled](#)]: enables or disables the “Logic Functions” tab in the tree on the left. For more information, see section 2.4.
- **Heartbeat (Periodic Alive Notification)**: this parameter lets the integrator incorporate a 1-Bit object to the project (“**[Heartbeat] Object to Send ‘1’**”) that will be sent periodically with value “1” to notify that the device is still working (*still alive*).

Note: *the first sending after download or bus failure takes place with a delay of up to 255 seconds, to prevent bus overload. The following ones match the period set.*

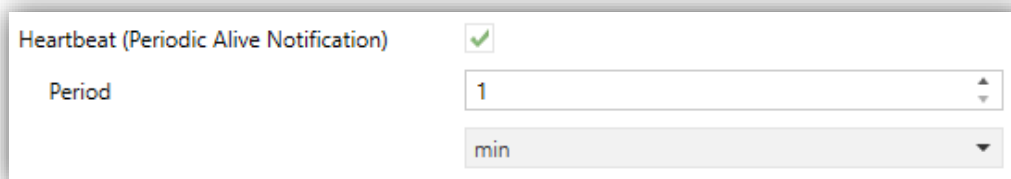

Figure 4. Heartbeat.

Regardless of the above parameters, the following objects are available by default:

- “[AC] On/Off” and “[AC] On/Off (Status)”: allow switching on (value “1”) and off (value “0”) the A/C unit or reading the current status, respectively.
- “[AC] Temperature Setpoint” and “[AC] Temperature Setpoint (Status)”: allow setting the desired temperature setpoint or reading the current value, respectively. See section 2.2.1 for further options.

¹ The default values of each parameter will be highlighted in blue in this document, as follows: [[default/rest of options](#)].

- “[AC] Mode” and “[AC] Mode (Status)”: allow setting the desired operation mode (either Automatic, Heating, Cooling, Fan or Dry) or reading the current mode, respectively. See section 2.2.1 for further options.
- “[AC] Fan: Percentage Control” and “[AC] Fan: Percentage Control (Status)”: allow establishing desired fan speed or reading the current fan speed, respectively. See section 2.2.2.
- Several **error objects**. See section 2.2.5.

2.2 A/C GATEWAY

2.2.1 CONFIGURATION

KLIC-SG vT allows controlling and monitoring an air-conditioning unit in the same way it would be through the wired remote control it is provided with.

Through the KNX bus, KLIC-SG vT can be sent orders to control the following basic functions of the air conditioning unit:

- **On/Off** switch of the air-conditioning unit.
- **Operation mode**: automatic, heating, cooling, fan and dry.
- **Temperature setpoint**, which can be modified within a 16-30°C range.
- **Fan speed**: 3 or 4 levels, depending on the model of the A/C unit.

Moreover, KLIC-SG vT allows configuring several advanced functions:

- **Simplified Operation Mode**, which allows switching between heating and cooling operation modes by means of a 1-bit object.
- **Fan**, which allows advanced configuration of the ventilation, see section 2.2.2.
- **Temperature measured by the AC unit**, which allows enabling an object which provides the value of the internal temperature probe. The automatic sending can be configured based on: a period of time, a change in value or a combination of both.
- **External reference temperature**, which allows enabling an object to use an external reference temperature, provided by a temperature probe.
- **Setpoint limits**, to restrict the range for the temperature setpoint.
- **Automatic off**, which allows an automatic and temporary switch-off of the unit (after a pre-established delay, if desired) when the communication object associated to this function is triggered due to a certain event.

- **Initial configuration**, which allows establishing the desired initial parameters for the state of the A/C unit after programming or restarting the device.
- **Scenes**, which allows defining predefined climate control environments, to be sent to the machine on the reception of scene orders from the KNX bus.
- **Operation time**, provides in hours and/or seconds the A/C unit operating time.
- **Wireless Remote Control Restriction**, which allows to disable wireless controller.
- **Filter**, which allows to know the filter status of the A/C Unit.
- **Ionizer**, which allows to activate the air purification function.

These functionalities imply changes in the state of the A/C unit, which therefore notifies KLIC-SG vT periodically about the current state. When KLIC-SG vT is notified about a change, it updates the **status objects** and sends them to the KNX bus. In addition, KLIC-SG vT provides an **error management** function (see section 2.2.5), which allows sending messages to the KNX bus in case the A/C unit reports any errors.

Important: *the functionality parametrised in KLIC-SG vT shall match the available functionality offered by the IDU, to prevent potential undesired behaviours.*

ETS PARAMETRISATION

The Configuration window under A/C Gateway provides the following parameters:

GENERAL	OPERATION MODES
- AC Gateway	Simplified Mode (Only Cooling/Heating) <input type="checkbox"/>
Configuration	VENTILATION
Fan	Fan <input checked="" type="checkbox"/>
	TEMPERATURE MEASURED BY THE AC
	Monitoring <input type="checkbox"/>
	REFERENCE TEMPERATURE
	External Reference Temperature Object <input type="checkbox"/>
	TEMPERATURE SETPOINT
	Setpoint Limits <input type="checkbox"/>
	AUTOMATIC OFF
	Automatic Off <input type="checkbox"/>
	INITIAL CONFIGURATION
	Initial Configuration <input checked="" type="radio"/> Default <input type="radio"/> Custom
	SCENES
	Scenes <input type="checkbox"/>
	OPERATION TIME
	Seconds <input type="checkbox"/>
	Hours <input type="checkbox"/>
	WIRELESS REMOTE CONTROL RESTRICTION
	Disable Remote Control <input type="checkbox"/>
	FILTER
	Filter <input type="checkbox"/>
	IONIZER
	Ionizer <input type="checkbox"/>

Figure 5. A/C Gateway. Configuration.

OPERATION MODES

OPERATION MODES
Simplified Mode (Only Cooling/Heating) <input type="checkbox"/>

Figure 6. A/C Gateway. Configuration. Operation modes.

KLIC-SG vT allows controlling the A/C unit operating mode through the following objects, available by default:

- “[AC] Mode”: 1-Byte object which allows selecting the A/C unit operation mode. There will be only taken in account values that are appropriated with some of available modes in Samsung units, which are represented in Table 1.
- “[AC] Mode (status)”: 1-Byte object which allows knowing the A/C unit operating mode status.

Object Value	A/C unit mode
0	Auto
1	Heating
3	Cooling
9	Fan only
14	Dry

Table 1. A/C unit operating modes.

Additionally, a simplified mode can be configured to select Cooling and Heating mode.

- **Simplified Mode (Only Cooling/Heating)** [*disabled/enabled*]: in addition to the “Mode” and “Mode (Status)” 1-Byte objects, available by default, it is possible to commute and to verify the current operation mode through the following 1-Bit objects, which get enabled after activating this parameter:
 - “Simplified Mode”, which allows switching to the Cooling mode by sending it a “0” and to the Heating mode by sending it a “1”.
 - “Simplified Mode (Status)”, which will send a value of “0” when the mode switches to Cooling or to Dry, or a value of “1” when it switches to Heating. The Fan and Auto modes are not reflected in the value of this object.

VENTILATION



Figure 7. A/C Gateway. Configuration. Ventilation.

- **Fan** [*disabled/enabled*]: enables the “Fan” tab, for advanced configuration of the fan functions. See section 2.2.2.

TEMPERATURE MEASURED BY THE A/C UNIT

TEMPERATURE MEASURED BY THE AC	
Monitoring	<input checked="" type="checkbox"/>
Sending Type	Periodic + Variation
Period	15
	min

Figure 8. A/C Gateway. Configuration. Temperature measured by the A/C unit.

- **Monitoring** [*disabled/enabled*]: enables the “[AC] AC Unit Measured Temperature” two-byte object, which provides the value of its internal temperature sensor, which is used by the AC machine to execute the control loop. Once enabled, a secondary parameter will show:
 - **Sending Type** [*Variation / Periodic / Periodic + Variation*]: sets whether the above object should be sent only in case of a change in the value, periodically in both cases, respectively. The latter two options bring entail one more parameter:
 - **Period** [*1...3600*][s] [*1...15...1440*][min] [*1...24*][h]: sets the cycle time for the periodic sending.

REFERENCE TEMPERATURE

REFERENCE TEMPERATURE	
External Reference Temperature Object	<input type="checkbox"/>

Figure 9. A/C Gateway. Configuration. Reference temperature.

- **External Reference Temperature Object** [*disabled/enabled*]: enables the “[AC] External Reference Temperature” 2-Byte object, which provides the value of an external temperature sensor, which is used by the AC machine as the reference to execute the control loop.

If during 3 minutes, no temperature values are received, values of the internal probe will be recuperated again to execute temperature control, in the same way as it will be controlled if KLIC-SG vT was configured disabling this option. If a new external temperature value is received, the control will be executed again by using this external value. The range of values allowed for this object is [0-70] °C, if different values are received, they will be ignored.

TEMPERATURE SETPOINT

The following objects to control and supervise setpoint temperature will be available by default:

- “[AC] Temperature Setpoint”: 2-Byte object to select decimal temperature values that belong to the range [16°-30°].
- “[AC] Temperature Setpoint (Status)”: 2-Byte object that provides the temperature setpoint status.

Note: A X.Y value will be rounded to X.0 if [Y < 5] or to X.5 if [Y ≥ 5].

Status object will be updated to the last setpoint temperature value received by the A/C unit after a complete communication cycle and will be sent to KNX bus every time that its value changes.

Last setpoint temperature that was set in either mode, will be stored and sent to the machine each time the operation mode is changed. Thus, a change in the setpoint temperature is done exclusively for the current operation mode of the machine.

Setpoint limits can be configured by parameter:

- **Setpoint Limits** [*disabled/enabled*]: allows restricting the range of the temperature setpoint (from below in the Cooling and Auto modes and from above in the Heating and Auto modes), provided that the limits are still within the predefined limits of the A/C unit. When KLIC-SG vT receives an order to send the A/C unit a setpoint which is greater (or lower) than the configured limits, it will actually send the limit value.
 - **Minimum (Cooling / Auto Mode)** [*16...18...30*] °C: sets the upper limit.
 - **Maximum (Heating / Auto Mode)** [*16...30*] °C: sets the lower limit.

TEMPERATURE SETPOINT	
Setpoint Limits	<input checked="" type="checkbox"/>
Minimum (Cooling/Dry/Auto Mode)	<input type="text" value="18"/> °C
Maximum (Heating/Auto Mode)	<input type="text" value="30"/> °C

Figure 10. A/C Gateway. Configuration. Temperature setpoint.

Once these limits are enabled, several objects to modify them at run time will be available. The values of this objects will be restricted to an interval which is defined by the absolute limits established by the A/C unit (16°C to 30°C).

- “[AC] Temperature Setpoint: Lower Limit”: 2-Byte object that allows changing the lower limit at run time.
- “[AC] Temperature Setpoint: Lower Limit (Status)”: 2-Byte object with the lower limit current value.
- “[AC] Temperature Setpoint: Upper Limit”: 2-Byte object that allows changing the upper limit at run time.
- “[AC] Temperature Setpoint: Upper Limit (Status)”: 2-Byte object with the upper limit current value.

Notes:

- *If [Minimum] ≥ [Maximum], limits will not be taken in account in Auto mode due to the incongruity. In this case, default values will be used.*
- *These parameters only can be set as integer values in ETS. However, at run time the associated objects allow decimal values.*
- *The A/C unit set a fixed temperature setpoint of 24°C in Fan mode and will ignore any setpoint temperature value received.*
- *The setpoint limits set by the A/C unit on each operating mode are indicated in Table 2, however, these limits can be more restrictive changing the configuration with the wired remote control:*

Mode	Temperature Setpoint
Auto	[18°-30°]
Cooling	[18°-30°]
Heating	[16°-30°]
Fan	Not available
Dry	[18°-30°]

Table 2. Interior setpoint limits of A/C unit

AUTOMATIC OFF

Figure 11. A/C Gateway. Configuration. Automatic off.

- **Automatic Off** [*disabled/enabled*]: enables the “[AC] Automatic Off” and “[AC] Automatic Off (Status)” binary objects, which lets performing a temporary switch-off of the A/C unit by sending it a value of “1” and a later switch-on by sending it a value of “0”. This object will be typically linked to a window sensor or a similar event trigger. Automatic off will be also active if the unit is previously in off state, so, the unit will not be able of being on until this situation finishes.

During the temporary switch-off state, KLIC-SG vT will still monitor any control orders being received (setpoint, fan speed, etc.), so they can be applied once it leaves such state.

- **Automatic Off Object Polarity** [*0 = Activate; 1 = Deactivate / 0 = Deactivate; 1 = Activate*]: sets the polarity of the above object.
- **Automatic Off Delay** [*1...60...3600*] s: sets the time KLIC-SG vT waits before switching the A/C machine off. Any switch-off order received during the delay will abort the time count. This delay can be changed at run time by using the object “[AC] Automatic Off: Delay”. Sending the value “0” disables the Automatic Off functionality.

INITIAL CONFIGURATION



Figure 12. A/C Gateway. Configuration. Initial Configuration.

- **Initial Configuration:** allows setting the desired initial state that KLIC-SG vT will send the A/C unit after programming or restarting the device:
 - [[Default](#)]: the initial state will be the last one KLIC-SG vT is aware of.
 - [[Custom](#)]: see section 2.2.3.

SCENES



Figure 13. A/C Gateway. Configuration. Scenes.

- **Scenes** [[disabled/enabled](#)]: allows setting up different scenes (up to 5), consisting each of them in a set of orders to be sent to the A/C unit upon the reception of scene trigger values through the KNX bus. See section 2.2.4.

OPERATING TIME

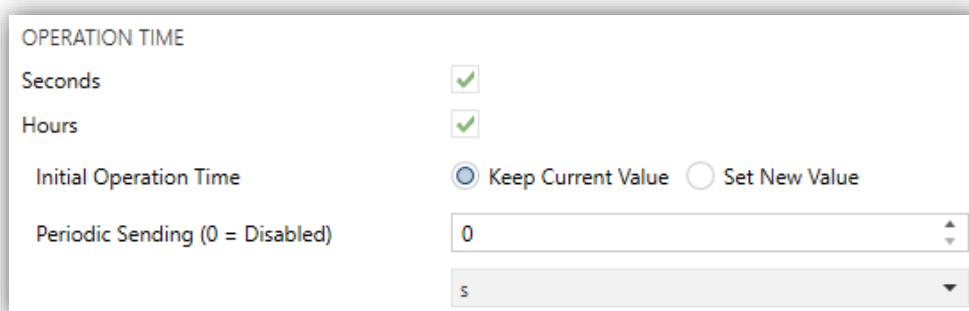

Figure 14. A/C Gateway. Configuration. Operating Time.

The operating time of the A/A machine in hours and/or seconds can be known.

The available parameters in ETS are:

- **Seconds** [*disabled/enabled*]: enables the 2-Byte object “[AC] Operating time (s)”. This object can be read and overwritten during executing time.
- **Hours** [*disabled/enabled*]: enables the 4-Byte object “[AC] Operating time (h)”. This object can be read and overwritten during executing time.
- **Initial Operation Time**, two options are available:
 - [*Keep current value*]: keeps the previous value.
 - [*Set new value*]: establishes an initial operating time **value** *[0...3600][s]* / *[0...65535][h]*.
- **Periodic Sending** *[0...3600][s]* / *[0...65535][min/h]*: operating time retransmission period. If set to 0 the periodic send is disabled.

When operating time object reaches its maximum value (65535h), it will be sent through KNX bus (in spite of the fact that the periodical sending has not been configured) and it will keep this value until the user reset it.

WIRELESS REMOTE CONTROL RESTRICTION

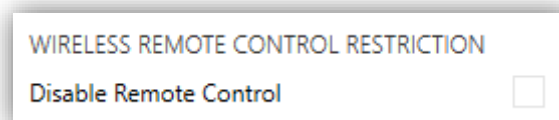

Figure 15. A/C Gateway. Configuration. Wireless Remote Control Restriction.

- **Disable Remote Control** [*disabled/enabled*]: when this option is enabled, it is not allowed to control the IDU via the wireless controller. At the same time, the objects “[AC] Remote Control Restriction” y “[AC] Remote Control Restriction (Status)” are enabled, so that the remote control can be re-enabled if desired.

FILTER



Figure 16. A/C Gateway. Configuration. Filter.

- **Filter** [*disabled/enabled*]: enables 1-Bit objects “[AC] Filter (Status)” and “[AC] Filter: Reset”. “[AC] Filter (Status)” will send to the bus KNX the value “1” to indicate that the filter needs to be cleaned. Once the filter is cleaned, the alarm has to be reset through the object “[AC] Filter: Reset” sending the value “0” or “1”.

IONIZER



Figure 17. A/C Gateway. Configuration. Ionizer.

- **Ionizer** [*disabled/enabled*]: enables the object “[AC] Ionizer” y “[AC] Ionizer (Status)”, to activate the air purification mode.

2.2.2 FAN

In the “Fan” tab, KLIC-SG vT allows advanced configuration of the fan functionality. The following features are displayed:

- **360 CST**: allows configuration for 360 cassette unit, enabling custom objects and configurations for this type of IDU. See section 2.2.3 and 2.2.4.
- **Step Control (1 bit)**: allows to increase (value “1”) or decrease (value “0”) the current speed level sequentially.
- **Fan Speeds²**: allows 3 or 4 ventilation levels, depending on the A/C unit model.
- **Individual Object for Automatic Mode**: allows enable or disable automatic fan mode with a 1-bit object.
- **Individual Object for Fan Stop Indication**: allows to know if the IDU is in a protection stop with a 1-bit object.

² This option is only available if **360 CST** is not selected, in which case this parameter will not appear.

- **Flaps²**: allows control of the oscillation of the horizontal and vertical flaps.
- **Wind-Free**: allows the Wind-Free mode to be enabled for gentle room climate control.
- **Quiet mode**: allows to decrease the noise from the air conditioner operation.

ETS PARAMETRISATION

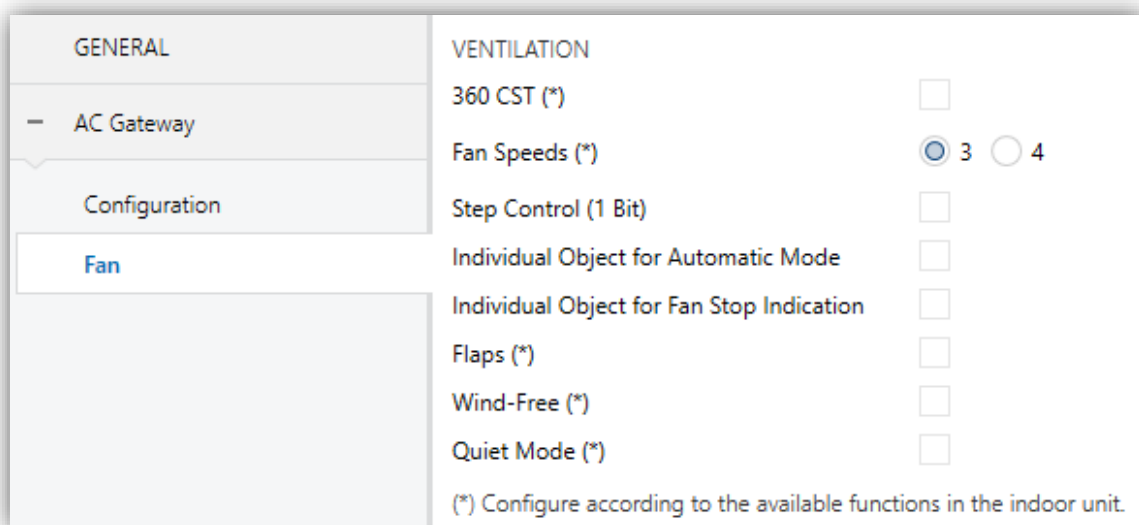

Figure 18. A/C Gateway. Fan.

- **360 CST** [*disabled/enabled*]: enables the objects “[AC] CST Air Flow” and “[AC] CST Air Flow (Status)” for airflow control of this IDU type.
- **Fan Speeds** [*3/4*]: specifies the number of the fan levels distinguished by A/C unit.

KLIC-SG vT allows the sending of fan speed orders to the A/C unit to switch the ventilation speed along the available levels. To that end, KLIC-SG vT provides a **percentage** control through the objects “[AC] Fan: **percentage control**” y “[AC] Fan: **percentage control (Status)**”, available by default.

Important: *fan speed must be configured according to the available functions in the A/C unit.*

Table 3 and Table 4 reflect the percentage values that refer to several ventilation levels:

Control Value	Status Value	Level sent to the A/C unit
0%	0%	0 (auto)
1-33%	33%	1 (low)
34-66%	66%	2 (medium)
67-100%	100%	3 (high)

Table 3. Fan Speed for 3 levels of ventilation.

Control Value	Status Value	Level sent to the A/C unit
0%	0%	0 (auto)
1-25%	25%	1 (low)
26-50%	50%	2 (medium)
51-75%	75%	3 (high)
76-100%	100%	4 (turbo)

Table 4. Fan Speed for 4 levels of ventilation.

Notes:

- *In automatic mode, it is not possible to know the effective fan speed, so, when this mode is activated, fan speed status will remain at 0% value.*
 - *In Dry and Auto mode, A/C unit sets fan speed in automatic mode. Due to this fact, fan speed control orders will be ignored during this mode. On the other hand, in Fan mode is not possible to send fan speed 0% (auto).*
- **Step Control (1 bit)** [*disabled/enabled*]: enables the “[AC] Fan: Step Control” one-bit object. If the parameter is enabled, the following options are displayed:
- **Non Cyclical:** the automatic mode will be ahead the minimum speed (speed 1): **Auto ↔ Minimum ↔ ... ↔ Maximum.**
 - **Cyclical:** the automatic mode will be between the maximum speed (speed n) and the minimum speed (speed 1): **Auto ↔ Minimum ↔ ... ↔ Maximum ↔ Auto ↔ Minimum ↔ ...**

Automatic fan speed mode can also be activated through a one-bit object that will appear activating the following parameter:

- **Individual Object for Automatic Mode** [*disabled/enabled*]: enables the “[AC] Fan: Automatic” and “[AC] Fan: Automatic (Status)” one-bit objects, which

will let activating/deactivating the automatic mode or reading the current status, respectively. Moreover, the polarity can be configured by parameter:

- **Automatic Mode Object Polarity** [*0 = Automatic On; 1 = Automatic Off* / *0 = Automatic Off; 1 = Automatic On*]: sets the polarity of the above objects.

If the individual object for automatic mode is enabled, the behaviour is as follows:

- When automatic mode is activated, fan percentage status will be 0%.
- When automatic mode is deactivated, fan speed level 1 will be set.

Additionally, the individual object parameter for **fan stop indication** can be configured:

- **Individual Object for Fan Stop Indication** [*disabled/enabled*]: enables the “[AC] Fan: Protection Stop” one-bit object, which will inform if the A/C Unit has done a protective stop. Moreover, the polarity can be configured by parameter:
 - **Fan Stop Object Polarity** [*0 = Fan Stop Protection; 1 = Normal Operation* / *0 = Normal Operation; 1 = Fan Stop Protection*]: sets the polarity of the above object.
- **Flaps** [*disabled/enabled*]: enables the horizontal and vertical flaps selection boxes.
 - **Horizontal Flaps** [*disabled/enabled*]: enables the “[AC] Horizontal Flaps: Swing” and “[AC] Horizontal Flaps: Swing (Status)” one-bit objects.
 - **Vertical Flaps** [*disabled/enabled*]: enables the “[AC] Vertical Flaps: Swing” and “[AC] Vertical Flaps: Swing (Status)” one-bit objects.

In addition, the polarity of both objects can be configured by parameter:

- **Swing Object Polarity** [*0 = Swing On; 1 = Swing Off* / *0 = Swing Off; 1 = Swing On*]: defines which value activates each swing.

The **Wind-Free** mode disperses the air evenly, creating a comfortable smooth environment and it is activated by the following parameter:

- **Wind-Free** [*disabled/enabled*]: enables the “[AC] Wind-Free Mode” and “[AC] Wind-Free Mode (Status)” one-bit objects, which will let activating/deactivating the Wind-Free mode or reading the current status, respectively.

Note: *Wind-Free mode will be deactivated when mode is changed, when quiet mode is activated or when the A/C unit is switched off.*

Quiet mode will decrease the noise from the air conditioner and it is activated by the following parameter:

- **Quiet Mode** [*disabled/enabled*]: enables the “[AC] Quiet Mode” and “[AC] Quiet Mode (Status)” one-bit objects, which will let activating/deactivating the quiet mode or reading the current status, respectively.

Note: *Quiet mode will be deactivated in fan mode, when Wind-Free mode is activated or when the A/C unit is switched off.*

2.2.3 INITIAL CONFIGURATION

The custom initial configuration allows setting the desired status that KLIC-SG vT will send the A/C unit after downloading or restarting the device. This status is defined in terms of on/off, mode, fan speed, air flow direction, flaps (horizontal and vertical) and temperature setpoint.

In addition, it is possible to activate an initial sending of this status to the KNX bus.

ETS PARAMETRISATION

After selecting “Custom” for the Initial Configuration option under the Configuration tab (see section 2.2.1), a new tab named Initial Configuration is displayed with the following parameters:

On/Off	Last (Before Restart) ▼
Mode	Last (Before Restart) ▼
Fan Speed	Last (Before Restart) ▼
Horizontal Flaps	Last (Before Restart) ▼
Vertical Flaps	Last (Before Restart) ▼
Setpoint	<input type="checkbox"/>
Value	Last (Before Restart)
Send Initial Configuration	<input type="checkbox"/>

Figure 19. A/C Gateway. Initial Configuration.

- On/Off [[Last \(Before Restart\)](#) / On / Off].
- Mode [[Last \(Before Restart\)](#) / Automatic / Heating / Cooling / Fan / Dry].
- Fan speed [[Last \(Before Restart\)](#) / Auto / 1 / 2 / 3]. The number of speeds (“Auto / 1 / 2 / 3” or “Auto / 1 / 2 / 3 / 4”) will depend on those selected in the **Fan speeds** parameter, in the “Fan” tab. See section 2.2.2.
- Air Flow Direction³ [[Last \(Before Restart\)](#) / Spot / Mid / Wide / Swing].
- Horizontal Flaps [[Last \(Before Restart\)](#) / Swing Off / Swing On].
- Vertical Flaps [[Last \(Before Restart\)](#) / Swing Off / Swing On].
- Setpoint [[disabled/enabled](#)]:
 - Value:
 - [[Last \(Before Restart\)](#)]: the value of the setpoint temperature will be kept. Only available if the **Setpoint** parameter remains disabled.
 - [[16...25...30](#)] °C.

Note: *this initial setpoint value may be modified by the setpoint limits during runtime.*

- **Send initial configuration** [[disabled/enabled](#)]: If enabled, the status objects will be sent to the KNX bus after applying the parametrized **delay** [0...[10](#)...3600], in seconds.

Notes:

- *Even if this option is not enabled, the status objects may be sent to the KNX bus if the initial configuration differs from the current status of the A/C machine.*
- *The delay parametrized in initial configuration sending is approximate, due to it starts to be counted when the communication between KLIC-SG vT and A/C unit is confirmed.*

³ This option is only available if **360 CST** is selected in the “Fan” tab.

2.2.4 SCENES

The Scenes function allows defining a set of statuses (in terms of On/Off, mode, fan speed, etc.) that KLIC-SG vT will send to the A/C unit whenever it receives the corresponding scene values from the KNX bus.

ETS PARAMETRISATION

After enabling this function (see section 2.2.1), a new tab named **Scenes** will be incorporated to the tab tree. It allows setting up different scenes (up to 5), consisting each of them in a set of orders to be sent to the A/C unit upon the reception, through the KNX bus and by means of the Scenes object, of the corresponding scene value (decreased by 1, according to the KNX standard).

Scene 1	<input checked="" type="checkbox"/>
Scene Number	1
On/Off	No Change
Mode	No Change
Fan Speed	No Change
Horizontal Flaps	No Change
Vertical Flaps	No Change
Setpoint	<input type="checkbox"/>
Value	No Change
Scene 2	<input type="checkbox"/>
Scene 3	<input type="checkbox"/>
Scene 4	<input type="checkbox"/>
Scene 5	<input type="checkbox"/>

Figure 20. A/C Gateway. Scenes.

For every enabled scene, the particular parameters that should be configured are:

- **Scene number** [[1...64](#)]: sets the scene number that, upon reception through the object “[AC] Scene” (decreased by one), will trigger the corresponding orders, as defined next:
 - **On/Off** [[No change](#) / [On](#) / [Off](#)]. If “No change” is selected, the machine will retain the last state before scene reception.
 - **Mode** [[Last \(before restart\)](#) / [Automatic](#) / [Heating](#) / [Cooling](#) / [Fan](#) / [Dry](#)].
 - **Fan speed** [[No change](#) / [Auto](#) / [1](#) / [2](#) / [3](#)]. The number of speeds (“[Auto](#) / [1](#) / [2](#) / [3](#)” or “[Auto](#) / [1](#) / [2](#) / [3](#) / [4](#)”) will depend on those selected in the **Fan speeds** parameter, in the “Fan” tab. See section 2.2.2.
 - **Air Flow Direction**⁴ [[No Change](#) / [Spot](#) / [Mid](#) / [Wide](#) / [Swing](#)].
 - **Horizontal Flaps** [[No Change](#) / [Swing Off](#) / [Swing On](#)].
 - **Vertical Flaps** [[No Change](#) / [Swing Off](#) / [Swing On](#)].
 - **Setpoint** [[disabled](#)/[enabled](#)]:
 - **Value:**
 - [[No change](#)]: the value of the setpoint temperature will be kept. Only available if the **Setpoint** parameter remains disabled.
 - [[16...25...30](#)] °C.

Note: *this setpoint value may be modified by the setpoint limits during runtime.*

2.2.5 ERROR HANDLING

KLIC-SG vT is capable of managing two error types:

- **Communication or internal errors:** errors in the communication process between KLIC-SG vT and the A/C unit:
 - **Communication error:** KLIC-SG vT is not able to establish communication with the A/C machine.

⁴ This option is only available if **360 CST** is selected in the “Fan” tab.

There is a LED notification, by which the LED on the device will light green when communication error is active.

- **Wrong acknowledgement:** KLIC-SG vT received an unexpected response after sending a request to the A/C unit.

There is a LED notification, by which the LED on the device will blink every 0.5 seconds in green and stay off for other 3 seconds when wrong acknowledgement error is active.

- **Errors in the A/C unit:** errors reported by the A/C unit itself. KLIC-SG vT can notify the KNX bus about the reported error code, although referring to the specific documentation of the A/C machine is advisable in order to obtain further information.

ETS PARAMETRISATION

The error handling function does not entail any parameter configuration. The following objects are available by default:

- Internal error objects:
 - “[AC] Internal Error: Communication”: 1-Bit object to indicate that KLIC-SG vT is unable to access to the internal communication port.
 - “[AC] Internal Error: Wrong Acknowledgement”: 1-Bit object to indicate that an unexpected response or a response with transmission errors has been received.

In case any of the above errors is detected, the corresponding object will be sent (with a value of “1”) to the KNX bus. Once the error is over, it the object will be sent with a value of “0”.

In case of being in an internal error situation, control orders will be ignored by KLIC-SG vT and the status will be the previous to the error activation.

Note: *If internal communication error is activated, the following steps should be taken:*

- 1) *Check that KLIC-SG vT is correctly connected to the A/C unit (IDU).*

- 2) *Reset the A/C unit (IDU).*
- 3) *If wired control is available, check if it reports any error.*
- 4) *If internal communication error is still active, contact technical support.*

● Errors in the A/C machine:

- “[AC] A/C Unit Error: Active Error”: 1-Bit object which indicate that there is an error in the A/C unit.
- “[AC] A/C Unit Error: Error Code”: 14-Byte object that supplies the error code.

In case the A/C unit reports an error, the former object will be sent with value of “1”, while the latter will report the corresponding error code. Once the error is over, both binary and 14-byte objects will send a value of “0”. Please, refer to the user manual of the A/C unit for details about the error codes.

2.3 INPUTS

KLIC-SG vT incorporates **two analogue/digital inputs**, each configurable as a:

- **Binary Input**, for the connection of a pushbutton or a switch/sensor.
- **Temperature Probe**, for the connection of a temperature sensor from Zennio.
- **Motion Detector**, for the connection of a motion detector from Zennio.

2.3.1 BINARY INPUT

Please refer to the “**Binary Inputs**” user manual, available in the KLIC-SG vT product section, at the Zennio website (www.zennio.com).

2.3.2 TEMPERATURE PROBE

Please refer to the “**Temperature Probe**” user manual, available in the KLIC-SG vT product section, at the Zennio website (www.zennio.com).

2.3.3 MOTION DETECTOR

Please refer to the “**Motion Detector**” user manual, available in the KLIC-SG vT product section, at the Zennio website (www.zennio.com).

2.4 LOGIC FUNCTIONS

This module makes it possible to perform numeric and binary operations with incoming values received from the KNX bus, and to send the results through other communication objects specifically enabled for this purpose.

KLIC-SG vT can implement **up to 10 different and independent functions**, each of them entirely customisable and consisting in **up to 4 consecutive operations each**.

The execution of each function can depend on a configurable **condition**, which will be evaluated every time the function is **triggered** through specific, parameterisable communication objects. The result after executing the operations of the function can also be evaluated according to certain **conditions** and afterwards sent (or not) to the KNX bus, which can be done every time the function is executed, periodically or only when the result differs from the last one.

Please refer to the “**Logic Functions**” user manual (available in the KLIC-SG vT product section at the Zennio homepage, www.zennio.com) for detailed information about the functionality and the configuration of the related parameters.

ANNEX I. COMMUNICATION OBJECTS

- “Functional range” shows the values that, with independence of any other values permitted by the bus according to the object size, may be of any use or have a particular meaning because of the specifications or restrictions from both the KNX standard or the application program itself.

Number	Size	I/O	Flags	Data type (DPT)	Functional Range	Name	Function
1	1 Byte	I/O	C R W T U	DPT_SceneControl	0-63; 128-191	[AC] Scene	0 - 63 (Execute 1 - 64); 128 - 129 (Save 1 - 64)
2	1 Bit	I	C - W - -	DPT_Switch	0/1	[AC] On/Off	0 = Off; 1 = On
3	1 Bit	O	C R - T -	DPT_Switch	0/1	[AC] On/Off (Status)	0 = Off; 1 = On
4	2 Bytes	I	C - W - -	DPT_Value_Temp	-273.00° - 670433.28°	[AC] Temperature Setpoint	[16 ... 30] °C
5	2 Bytes	O	C R - T -	DPT_Value_Temp	-273.00° - 670433.28°	[AC] Temperature Setpoint (Status)	[16 ... 30] °C
6	2 Bytes	I	C - W - -	DPT_Value_Temp	-273.00° - 670433.28°	[AC] Temperature Setpoint: Lower Limit	[16 ... 30] °C
7	2 Bytes	O	C R - T -	DPT_Value_Temp	-273.00° - 670433.28°	[AC] Temperature Setpoint: Lower Limit (Status)	[16 ... 30] °C
8	2 Bytes	I	C - W - -	DPT_Value_Temp	-273.00° - 670433.28°	[AC] Temperature Setpoint: Upper Limit	[16 ... 30] °C
9	2 Bytes	O	C R - T -	DPT_Value_Temp	-273.00° - 670433.28°	[AC] Temperature Setpoint: Upper Limit (Status)	[16 ... 30] °C
10	1 Byte	I	C - W - -	DPT_HVACContrMode	0=Auto 1=Heat 3=Cool 9=Fan 14=Dry	[AC] Mode	0 = Automatic; 1 = Heating; 3 = Cooling; 9 = Fan; 14 = Dry
11	1 Byte	O	C R - T -	DPT_HVACContrMode	0=Auto 1=Heat 3=Cool 9=Fan 14=Dry	[AC] Mode (Status)	0 = Automatic; 1 = Heating; 3 = Cooling; 9 = Fan; 14 = Dry
12	1 Bit	I	C - W - -	DPT_Heat_Cool	0/1	[AC] Simplified Mode	0 = Cooling; 1 = Heating
13	1 Bit	O	C R - T -	DPT_Heat_Cool	0/1	[AC] Simplified Mode (Status)	0 = Cooling; 1 = Heating
14	1 Byte	I	C - W - -	DPT_Scaling	0% - 100%	[AC] Fan: Percentage Control	0% = Auto; [0,4..25,1] % = S1; [25,5..50,2] % = S2; [50,6..75,3] % = S3; [75,5..100] % = S4
	1 Byte	I	C - W - -	DPT_Scaling	0% - 100%	[AC] Fan: Percentage Control	0% =Auto; [0,4...33.33] % = S1; [33.73...66.67] % = S2; [67.06...100] % = S3

15	1 Byte	O	CR-T-	DPT_Scaling	0% - 100%	[AC] Fan: Percentage Control (Status)	Auto = 0%; S1 = 25,1%; S2 = 50,2%; S3 = 75,3%; S4 = 100%
	1 Byte	O	CR-T-	DPT_Scaling	0% - 100%	[AC] Fan: Percentage Control (Status)	Auto = 0%; S1 = 33.33%; S2 = 66.67%; S3 = 100%
16	1 Bit	I	C-W--	DPT_Enable	0/1	[AC] Fan: Automatic	0 = Automatic On; 1 = Automatic Off (Speed 1)
	1 Bit	I	C-W--	DPT_Enable	0/1	[AC] Fan: Automatic	0 = Automatic Off (Speed 1); 1 = Automatic On
17	1 Bit	O	CR-T-	DPT_Enable	0/1	[AC] Fan: Automatic (Status)	0 = Automatic On; 1 = Automatic Off
	1 Bit	O	CR-T-	DPT_Enable	0/1	[AC] Fan: Automatic (Status)	0 = Automatic Off; 1 = Automatic On
18	1 Bit	I	C-W--	DPT_Step	0/1	[AC] Fan: Step Control	0 = Down; 1 = Up
19	1 Bit	O	CR-T-	DPT_Bool	0/1	[AC] Fan: Protection Stop	0 = Normal Operation; 1 = Stop Protection Activated
	1 Bit	O	CR-T-	DPT_Bool	0/1	[AC] Fan: Protection Stop	0 = Stop Protection Activated; 1 = Normal Operation
20	1 Byte	I	C-W--	1.xxx	0/1	[AC] 360 CST Air Flow	0 = Spot; 1 = Mid; 2 = Wide; 3 = Swing
21	1 Byte	O	CR-T-	1.xxx	0/1	[AC] 360 CST Air Flow (Status)	0 = Spot; 1 = Mid; 2 = Wide; 3 = Swing
22	1 Bit	I	C-W--	DPT_Switch	0/1	[AC] Horizontal Flaps: Swing	0 = Swing Off; 1 = Swing On
	1 Bit	I	C-W--	DPT_Switch	0/1	[AC] Horizontal Flaps: Swing	0 = Swing On; 1 = Swing Off
23	1 Bit	O	CR-T-	DPT_Switch	0/1	[AC] Horizontal Flaps: Swing (Status)	0 = Swing Off; 1 = Swing On
	1 Bit	O	CR-T-	DPT_Switch	0/1	[AC] Horizontal Flaps: Swing (Status)	0 = Swing On; 1 = Swing Off
24	1 Bit	I	C-W--	DPT_Switch	0/1	[AC] Vertical Flaps: Swing	0 = Swing Off; 1 = Swing On
	1 Bit	I	C-W--	DPT_Switch	0/1	[AC] Vertical Flaps: Swing	0 = Swing On; 1 = Swing Off
25	1 Bit	O	CR-T-	DPT_Switch	0/1	[AC] Vertical Flaps: Swing (Status)	0 = Swing Off; 1 = Swing On
	1 Bit	O	CR-T-	DPT_Switch	0/1	[AC] Vertical Flaps: Swing (Status)	0 = Swing On; 1 = Swing Off
26	2 Bytes	I	C-W--	DPT_Value_Temp	-273.00° - 670433.28°	[AC] External Reference Temperature	[0 ... 70] °C
27	2 Bytes	O	CR-T-	DPT_Value_Temp	-273.00° - 670433.28°	[AC] AC Unit Meseasured Temperature	Temperature from the internal sensor (°C)
28	1 Bit	I	C-W--	DPT_Switch	0/1	[AC] Automatic Off	0 = Deactivate; 1 = Activate
	1 Bit	I	C-W--	DPT_Switch	0/1	[AC] Automatic Off	0 = Activate; 1 = Deactivate
29	1 Bit	O	CR-T-	DPT_Switch	0/1	[AC] Automatic Off (Status)	0 = Deactivated; 1 = Activated
	1 Bit	O	CR-T-	DPT_Switch	0/1	[AC] Automatic Off (Status)	0 = Activated; 1 = Deactivated
30	2 Bytes	I	C-W--	DPT_TimePeriodSec	0 - 65535	[AC] Automatic Off: Delay	[0...3600] s (0 = Disabled)
31	4 Bytes	I/O	CRWT-	DPT_LongDeltaTimeSec	-2147483648 - 2147483647	[AC] Operating Time (s)	Operation time in seconds
32	2 Bytes	I/O	CRWT-	DPT_TimePeriodHrs	0 - 65535	[AC] Operating Time (h)	Operation time in hours
33	1 Bit	O	CR-T-	DPT_Alarm	0/1	[AC] Internal Error: Communication	Unable to Set AC Communication
34	1 Bit	O	CR-T-	DPT_Alarm	0/1	[AC] Internal Error: Wrong Acknowledgement	Acknowledgement Received with Errors

35	1 Bit	O	CR-T-	DPT_Alarm	0/1	[AC] AC Unit Error: Active Error	AC Unit Error
36	14 Bytes	O	CR-T-	DPT_String_ASCII		[AC] AC Unit Error: Error Code	See AC Unit Manual
37	1 Bit	I	C-W--	DPT_Enable	0/1	[AC] Remote Control Restriction	0 = Disable Remote Control; 1 = Enable Remote Control
38	1 Bit	O	CR-T-	DPT_Enable	0/1	[AC] Remote Control Restriction (Status)	0 = Remote Control Disabled; 1 = Remote Control Enabled
39	1 Bit	I	C-W--	DPT_Trigger	0/1	[AC] Filter: Reset	Filter Status Reset
40	1 Bit	O	CR-T-	DPT_Enable	0/1	[AC] Filter (Status)	0 = No Alarm; 1 = Alarm
41	1 Bit	I	C-W--	DPT_Switch	0/1	[AC] Wind-Free Mode	0 = Deactivate; 1 = Activate
42	1 Bit	O	CR-T-	DPT_Switch	0/1	[AC] Wind-Free Mode (Status)	0 = Deactivated; 1 = Activated
43	1 Bit	I	C-W--	DPT_Switch	0/1	[AC] Quiet Mode	0 = Deactivate; 1 = Activate
44	1 Bit	O	CR-T-	DPT_Switch	0/1	[AC] Quiet Mode (Status)	0 = Deactivated; 1 = Activated
45	1 Bit	I	C-W--	DPT_Switch	0/1	[AC] Ionizer	0 = Deactivate; 1 = Activate
46	1 Bit	O	CR-T-	DPT_Switch	0/1	[AC] Ionizer (Status)	0 = Deactivated; 1 = Activated
63, 67	2 Bytes	O	CR-T-	DPT_Value_Temp	-273.00° - 670433.28°	[Ix] Current Temperature	Temperature Sensor Value
64, 68	1 Bit	O	CR-T-	DPT_Alarm	0/1	[Ix] Overcooling	0 = No Alarm; 1 = Alarm
65, 69	1 Bit	O	CR-T-	DPT_Alarm	0/1	[Ix] Overheating	0 = No Alarm; 1 = Alarm
66, 70	1 Bit	O	CR-T-	DPT_Alarm	0/1	[Ix] Probe Error	0 = No Alarm; 1 = Alarm
71, 77	1 Bit	I	C-W--	DPT_Enable	0/1	[Ix] Input Lock	0 = Unlock; 1 = Lock
72, 78	1 Bit		C--T-	DPT_Switch	0/1	[Ix] [Short Press] 0	Sending of 0
	1 Bit		C--T-	DPT_Switch	0/1	[Ix] [Short Press] 1	Sending of 1
	1 Bit	I	C-WT-	DPT_Switch	0/1	[Ix] [Short Press] 0/1 Switching	Switching 0/1
	1 Bit		C--T-	DPT_UpDown	0/1	[Ix] [Short Press] Move Up Shutter	Sending of 0 (Up)
	1 Bit		C--T-	DPT_UpDown	0/1	[Ix] [Short Press] Move Down Shutter	Sending of 1 (Down)
	1 Bit		C--T-	DPT_UpDown	0/1	[Ix] [Short Press] Move Up/Down Shutter	Switching 0/1 (Up/Down)
	1 Bit		C--T-	DPT_Step	0/1	[Ix] [Short Press] Stop/Step Up Shutter	Sending of 0 (Stop/Step Up)
	1 Bit		C--T-	DPT_Step	0/1	[Ix] [Short Press] Stop/Step Down Shutter	Sending of 1 (Stop/Step Down)
	1 Bit		C--T-	DPT_Step	0/1	[Ix] [Short Press] Stop/Step Shutter (Switched)	Switching of 0/1 (Stop/Step Up/Down)
	4 Bit		C--T-	DPT_Control_Dimming	0x0 (Stop) 0x1 (Dec. by 100%) ... 0x7 (Dec. by 1%) 0x8 (Stop) 0xD (Inc. by 100%) ... 0xF (Inc. by 1%)	[Ix] [Short Press] Brighter	Increase Brightness
4 Bit		C--T-	DPT_Control_Dimming	0x0 (Stop) 0x1 (Dec. by 100%)	[Ix] [Short Press] Darker	Decrease Brightness	

				...		
				0x7 (Dec. by 1%) 0x8 (Stop) 0xD (Inc. by 100%) ...		
				0xF (Inc. by 1%)		
	4 Bit		C--T-	DPT_Control_Dimming	0x0 (Stop) 0x1 (Dec. by 100%) ...	[Ix] [Short Press] Brighter/Darker
				0x7 (Dec. by 1%) 0x8 (Stop) 0xD (Inc. by 100%) ...		Switch Bright/Dark
				0xF (Inc. by 1%)		
	1 Bit		C--T-	DPT_Switch	0/1	[Ix] [Short Press] Light On
	1 Bit		C--T-	DPT_Switch	0/1	[Ix] [Short Press] Light Off
	1 Bit	I	C-WT-	DPT_Switch	0/1	[Ix] [Short Press] Light On/Off
	1 Byte		C--T-	DPT_SceneControl	0-63; 128-191	[Ix] [Short Press] Run Scene
	1 Byte		C--T-	DPT_SceneControl	0-63; 128-191	[Ix] [Short Press] Save Scene
	1 Bit	I/O	CRWT-	DPT_Switch	0/1	[Ix] [Switch/Sensor] Edge
	1 Byte		C--T-	DPT_Value_1_Ucount	0 - 255	[Ix] [Short Press] Constant Value (Integer)
	1 Byte		C--T-	DPT_Scaling	0% - 100%	[Ix] [Short Press] Constant Value (Percentage)
	2 Bytes		C--T-	DPT_Value_2_Ucount	0 - 65535	[Ix] [Short Press] Constant Value (Integer)
	2 Bytes		C--T-	9.xxx	-671088.64 - 670433.28	[Ix] [Short Press] Constant Value (Float)
						Float Value
73, 79	1 Byte	I	C-W--	DPT_Scaling	0% - 100%	[Ix] [Short Press] Shutter Status (Input)
						0% = Top; 100% = Bottom
	1 Byte	I	C-W--	DPT_Scaling	0% - 100%	[Ix] [Short Press] Dimming Status (Input)
						0% - 100%
	1 Bit		C--T-	DPT_Switch	0/1	[Ix] [Long Press] 0
	1 Bit		C--T-	DPT_Switch	0/1	[Ix] [Long Press] 1
	1 Bit	I	C-WT-	DPT_Switch	0/1	[Ix] [Long Press] 0/1 Switching
	1 Bit		C--T-	DPT_UpDown	0/1	[Ix] [Long Press] Move Up Shutter
	1 Bit		C--T-	DPT_UpDown	0/1	[Ix] [Long Press] Move Down Shutter
	1 Bit		C--T-	DPT_UpDown	0/1	[Ix] [Long Press] Move Up/Down Shutter
	1 Bit		C--T-	DPT_Step	0/1	[Ix] [Long Press] Stop/Step Up Shutter
						Sending of 0 (Stop/Step Up)
	1 Bit		C--T-	DPT_Step	0/1	[Ix] [Long Press] Stop/Step Down Shutter
						Sending of 1 (Stop/Step Down)
74, 80	1 Bit		C--T-	DPT_Step	0/1	[Ix] [Long Press] Stop/Step Shutter (Switched)
						Switching of 0/1 (Stop/Step Up/Down)

	4 Bit		C--T-	DPT_Control_Dimming	0x0 (Stop) 0x1 (Dec. by 100%) ... 0x7 (Dec. by 1%) 0x8 (Stop) 0xD (Inc. by 100%) ... 0xF (Inc. by 1%)	[Ix] [Long Press] Brighter	Long Pr. -> Brighter; Release -> Stop
	4 Bit		C--T-	DPT_Control_Dimming	0x0 (Stop) 0x1 (Dec. by 100%) ... 0x7 (Dec. by 1%) 0x8 (Stop) 0xD (Inc. by 100%) ... 0xF (Inc. by 1%)	[Ix] [Long Press] Darker	Long Pr. -> Darker; Release -> Stop
	4 Bit		C--T-	DPT_Control_Dimming	0x0 (Stop) 0x1 (Dec. by 100%) ... 0x7 (Dec. by 1%) 0x8 (Stop) 0xD (Inc. by 100%) ... 0xF (Inc. by 1%)	[Ix] [Long Press] Brighter/Darker	Long Pr. -> Brighter/Darker; Release -> Stop
	1 Bit		C--T-	DPT_Switch	0/1	[Ix] [Long Press] Light On	Sending of 1 (On)
	1 Bit		C--T-	DPT_Switch	0/1	[Ix] [Long Press] Light Off	Sending of 0 (Off)
	1 Bit	I	C-WT-	DPT_Switch	0/1	[Ix] [Long Press] Light On/Off	Switching 0/1
	1 Byte		C--T-	DPT_SceneControl	0-63; 128-191	[Ix] [Long Press] Run Scene	Sending of 0 - 63
	1 Byte		C--T-	DPT_SceneControl	0-63; 128-191	[Ix] [Long Press] Save Scene	Sending of 128 - 191
	1 Bit	O	CR-T-	DPT_Alarm	0/1	[Ix] [Switch/Sensor] Alarm: Breakdown or Sabotage	1 = Alarm; 0 = No Alarm
	2 Bytes		C--T-	9.xxx	-671088.64 - 670433.28	[Ix] [Long Press] Constant Value (Float)	Float Value
	2 Bytes		C--T-	DPT_Value_2_Ucount	0 - 65535	[Ix] [Long Press] Constant Value (Integer)	0 - 65535
	1 Byte		C--T-	DPT_Scaling	0% - 100%	[Ix] [Long Press] Constant Value (Percentage)	0% - 100%
	1 Byte		C--T-	DPT_Value_1_Ucount	0 - 255	[Ix] [Long Press] Constant Value (Integer)	0 - 255
75, 81	1 Bit		C--T-	DPT_Trigger	0/1	[Ix] [Long Press/Release] Stop Shutter	Release -> Stop Shutter
76, 82	1 Byte	I	C-W--	DPT_Scaling	0% - 100%	[Ix] [Long Press] Dimming Status (Input)	0% - 100%
	1 Byte	I	C-W--	DPT_Scaling	0% - 100%	[Ix] [Long Press] Shutter Status (Input)	0% = Top; 100% = Bottom
83	1 Byte	I	C-W--	DPT_SceneNumber	0 - 63	[Motion Detector] Scene Input	Scene Value

84	1 Byte		C--T-	DPT_SceneControl	0-63; 128-191	[Motion Detector] Scene Output	Scene Value
85, 114	1 Byte	O	CR-T-	DPT_Scaling	0% - 100%	[Ix] Luminosity	0-100%
86, 115	1 Bit	O	CR-T-	DPT_Alarm	0/1	[Ix] Open Circuit Error	0 = No Error; 1 = Open Circuit Error
87, 116	1 Bit	O	CR-T-	DPT_Alarm	0/1	[Ix] Short Circuit Error	0 = No Error; 1 = Short Circuit Error
88, 117	1 Byte	O	CR-T-	DPT_Scaling	0% - 100%	[Ix] Presence State (Scaling)	0-100%
89, 118	1 Byte	O	CR-T-	DPT_HVACMode	1=Comfort 2=Standby 3=Economy 4=Building Protection	[Ix] Presence State (HVAC)	Auto, Comfort, Standby, Economy, Building Protection
90, 119	1 Bit	O	CR-T-	DPT_Switch	0/1	[Ix] Presence State (Binary)	Binary Value
	1 Bit	O	CR-T-	DPT_Ack	0/1	[Ix] Presence: Slave Output	1 = Motion Detected
91, 120	1 Bit	I	C-W--	DPT_Window_Door	0/1	[Ix] Presence Trigger	Binary Value to Trigger the Presence Detection
92, 121	1 Bit	I	C-W--	DPT_Start	0/1	[Ix] Presence: Slave Input	0 = Nothing; 1 = Detection from slave device
93, 122	2 Bytes	I	C-W--	DPT_TimePeriodSec	0 - 65535	[Ix] Presence: Waiting Time	0-65535 s.
94, 123	2 Bytes	I	C-W--	DPT_TimePeriodSec	0 - 65535	[Ix] Presence: Listening Time	1-65535 s.
95, 124	1 Bit	I	C-W--	DPT_Enable	0/1	[Ix] Presence: Enable	According to parameters
96, 125	1 Bit	I	C-W--	DPT_DayNight	0/1	[Ix] Presence: Day/Night	According to parameters
97, 126	1 Bit	O	CR-T-	DPT_Occupancy	0/1	[Ix] Presence: Occupancy State	0 = Not Occupied; 1 = Occupied
98, 127	1 Bit	I	C-W--	DPT_Start	0/1	[Ix] External Motion Detection	0 = Nothing; 1 = Motion detected by an external sensor
99, 104, 109, 128, 133, 138	1 Byte	O	CR-T-	DPT_Scaling	0% - 100%	[Ix] [Cx] Detection State (Scaling)	0-100%
100, 105, 110, 129, 134, 139	1 Byte	O	CR-T-	DPT_HVACMode	1=Comfort 2=Standby 3=Economy 4=Building Protection	[Ix] [Cx] Detection State (HVAC)	Auto, Comfort, Standby, Economy, Building Protection
101, 106, 111, 130, 135, 140	1 Bit	O	CR-T-	DPT_Switch	0/1	[Ix] [Cx] Detection State (Binary)	Binary Value
102, 107, 112, 131, 136, 141	1 Bit	I	C-W--	DPT_Enable	0/1	[Ix] [Cx] Enable Channel	According to parameters
103, 108, 113, 132, 137, 142	1 Bit	I	C-W--	DPT_Switch	0/1	[Ix] [Cx] Force State	0 = No Detection; 1 = Detection
143, 144, 145, 146, 147, 148, 149, 150, 151, 152, 153, 154, 155, 156, 157, 158, 159, 160, 161, 162, 163, 164, 165, 166, 167,	1 Bit	I	C-W--	DPT_Bool	0/1	[LF] (1-Bit) Data Entry x	Binary Data Entry (0/1)

168, 169, 170, 171, 172, 173, 174							
175, 176, 177, 178, 179, 180, 181, 182, 183, 184, 185, 186, 187, 188, 189, 190	1 Byte	I	C - W - -	DPT_Value_1_Ucount	0 - 255	[LF] (1-Byte) Data Entry x	1-Byte Data Entry (0-255)
191, 192, 193, 194, 195, 196, 197, 198, 199, 200, 201, 202, 203, 204, 205, 206	2 Bytes	I	C - W - -	DPT_Value_2_Ucount	0 - 65535	[LF] (2-Byte) Data Entry x	2-Byte Data Entry
				DPT_Value_2_Count	-32768 - 32767		
				DPT_Value_Tempo	-273, 00 - 670760, 00		
207, 208, 209, 210, 211, 212, 213, 214	4 Bytes	I	C - W - -	DPT_Value_4_Count	-2147483648 - 2147483647	[LF] (4-Byte) Data Entry x	4-Byte Data Entry
215, 216, 217, 218, 219, 220, 221, 222, 223, 224	1 Bit	O	CR - T -	DPT_Bool	0/1	[LF] Function x - Result	(1-Bit) Boolean
	1 Byte	O	CR - T -	DPT_Value_1_Ucount	0 - 255	[LF] Function x - Result	(1-Byte) Unsigned
	2 Bytes	O	CR - T -	DPT_Value_2_Ucount	0 - 65535	[LF] Function x - Result	(2-Byte) Unsigned
	4 Bytes	O	CR - T -	DPT_Value_4_Count	-2147483648 - 2147483647	[LF] Function x - Result	(4-Byte) Signed
	1 Byte	O	CR - T -	DPT_Scaling	0% - 100%	[LF] Function x - Result	(1-Byte) Percentage
	2 Bytes	O	CR - T -	DPT_Value_2_Count	-32768 - 32767	[LF] Function x - Result	(2-Byte) Signed
	2 Bytes	O	CR - T -	DPT_Value_Temp	-273.00° - 670433.28°	[LF] Function x - Result	(2-Byte) Float
225	1 Bit		C - - T -	DPT_Trigger	0/1	[Heartbeat] Object to Send '1'	Sending of '1' Periodically

Join and send us your inquiries
about Zennio devices:
<https://support.zennio.com/>

Zennio Avance y Tecnología S.L.
C/ Río Jarama, 132. Nave P-8.11
45007 Toledo (Spain).

Tel. +34 925 232 002.

www.zennio.com
info@zennio.com

