

MINiBOX 0-10V X3/X2/X1

Multifunction Actuator with 3/2/1 fold 0-10V analog input/output

ZIO3X010 / ZIO2X010 / ZIO1X010

Application program version: [1.3]

User manual edition: [1.3]_a

www.zennio.com

CONTENTS

Contents	2
Document Updates	3
1 Introduction	4
1.1 MINiBOX 0-10V X3/X2/X1	4
1.2 Installation.....	5
1.3 Start-Up and Power Loss	6
2 Configuration.....	7
2.1 General.....	7
2.2 Analog Input.....	10
2.3 Analog Voltage Output.....	11
2.3.1 Operating Time Counter	11
2.4 Fan Coil.....	13
2.5 Thermostats	14
2.6 Logic Functions.....	15
2.7 Manual Control	16
ANNEX I. Communication Objects.....	19

DOCUMENT UPDATES

Version	Changes	Page(s)
[1.3]_a	Changes in the software library: <ul style="list-style-type: none">• Keep saved scenes functionality added• Optimisation of the analog output, fan coil, thermostat and logic functions.	9 -
[1.2]_a	New devices: MINiBOX 0-10V X2 y MINiBOX 0-10V X1 Changes in the software library: <ul style="list-style-type: none">• Analog inputs module is added.• Optimisation of the analog output, heartbeat and fan coil.	-

1 INTRODUCTION

1.1 MINiBOX 0-10V X3/X2/X1

MINiBOX 0-10V from Zennio is a KNX actuator that aims at fulfilling the climate control needs of KNX environments with integrated fan coil units **consisting of two or four pipes**, where the valves in the pipes and the fan are controlled through **analog 0-10 VDC signals**.

This document describes the three versions of the device: MINiBOX 0-10V X3 (3 channels) / MINiBOX 0-10V X2 (2 channels) / MINiBOX 0-10V X1 (1 channel) and all their characteristics will be mentioned respectively and following this order along the entire document.

- **3 / 2 / 1 fan coil analog modules** to control 2 and 4 pipes units with 0-10V fan or valves.
- **3 / 2 / 1 independent 0-10V analog voltage outputs** configurable as fan or valve of a fan coil unit or other adjustable load between these voltage levels.
- **3 / 2 / 1 independent analog inputs** capable of measuring **voltage** (0...1V, 0...10V or 1...10V) and **current** (0...20mA or 4...20mA) signals.
- **3 / 2 / 1 independent thermostats**.
- **10 customisable, multi-operation logic functions**.
- **Manual operation / supervision** of the **outputs 0-10V** through the on-board pushbuttons and LEDs.
- **Heartbeat** or periodical "still-alive" notification.
- Possibility of **keeping saved scenes** or establishing those configured by parameters for the actions control.

1.2 INSTALLATION

The MINIBOX 0-10V devices connect to the KNX bus through the on-board KNX connector. Once the device is provided with power from the KNX bus, both the individual address and the associated application program may be downloaded.

This device does not need any additional external power since it is entirely powered through the KNX bus.

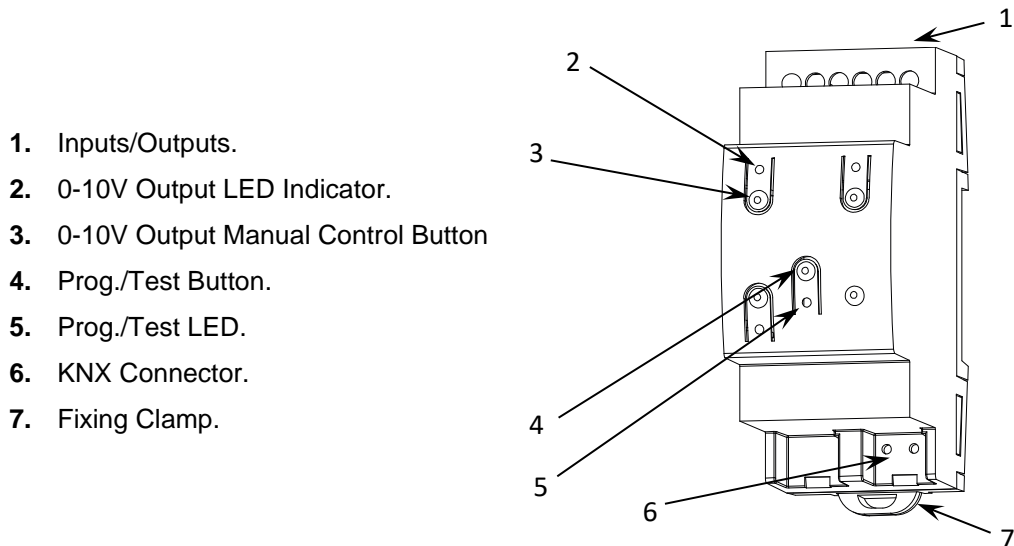

1. Inputs/Outputs.
2. 0-10V Output LED Indicator.
3. 0-10V Output Manual Control Button
4. Prog./Test Button.
5. Prog./Test LED.
6. KNX Connector.
7. Fixing Clamp.

Figure 1. MINIBOX 0-10V X3. Elements

Note: the previous figure is analogous for MINIBOX 0-10V X2 and MINIBOX 0-10V X1

The main elements of the device are described next.

- **Test/Prog. Button (4):** a short press on this button sets the device into the programming mode, making the associated **LED (5)** light in red.

Note: if this button is held while plugging the device into the KNX bus, the device will enter into **safe mode**. In such case, the LED will blink in red every 0.5 seconds.

- **Inputs/Outputs (1):** inputs/output ports for the insertion of the stripped cables of the systems being controlled by the actuator (see sections 2.2 and 2.3). Please secure the connection by means of the on-board screws.

To get detailed information about the technical features of this device, as well as on the installation and security procedures, please refer to the corresponding **Datasheet**, bundled with the original package of the device and also available at www.zennio.com.

1.3 START-UP AND POWER LOSS

Depending on the configuration, some specific actions will be performed during the start-up. For example, the integrator can set whether the output channels should switch to a particular state and whether the device should send certain objects to the bus after the power recovery. Please consult the next sections of this document for further details.

On the other hand, when a bus power failure takes place, the MINiBOX 0-10V devices will interrupt any pending actions and will save its state so it can be recovered once the power supply is restored. Also, after failure recovery, the analog outputs and fan coil module will switch to the specific state configured in ETS (if any).

2 CONFIGURATION

2.1 GENERAL

After importing the corresponding database in ETS and adding the device into the topology of the project, the configuration process begins by entering the Parameters tab of the device.

ETS PARAMETERISATION

The only parameterisable screen that is always available is “General”. From this screen it is possible to activate/deactivate all the required functionality. The following image corresponds to the MINiBOX 0-10V X3. The reduced versions only show the number of channels corresponding to each device.

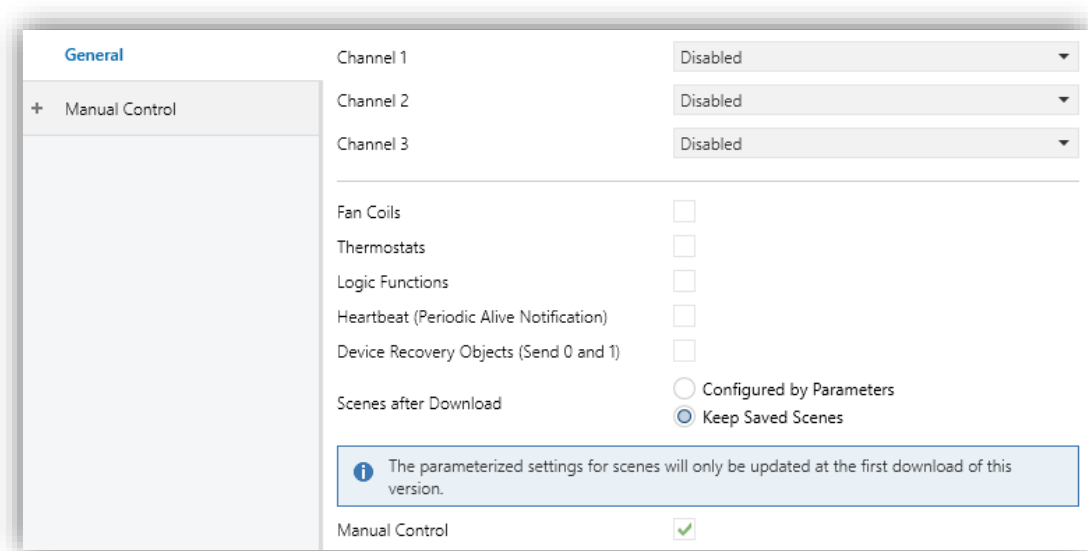
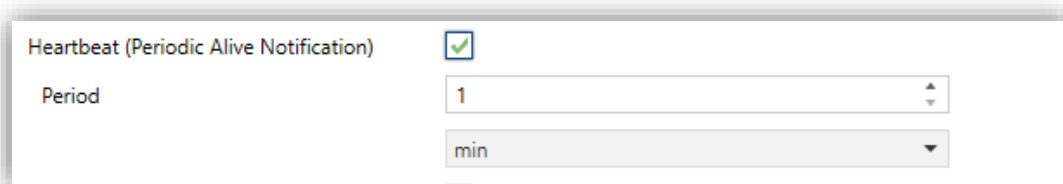

Figure 2. General. MINiBOX 0-10V X3

- **Channel X** [*disabled/input/output*]¹: enables or disables the “Analog Inputs” (see section 2.2) and/or “Analog Voltage Outputs” (see section 2.3) tabs on the left menu.

¹ The default values of each parameter will be highlighted in this document, as follows: [*default/rest of options*].

- **Fan Coils** [[disabled/enabled](#)]: enables or disables the “Fan Coil” tab on the left menu. See section 2.4 for more details.
- **Thermostats** [[disabled/enabled](#)]: enables or disables the “Thermostats” tab on the left menu. See section 2.5 for more details.
- **Logic Functions** [[disabled/enabled](#)]: enables or disables the “Logic Functions” tab on the left menu. See section 2.6 for more details.
- **Heartbeat (Periodical Alive Notification)** [[disabled/enabled](#)]: this parameter lets the integrator incorporate a one-bit object to the project (“**[Heartbeat] Object to Send ‘1’**”) that will be sent periodically with value “1” to notify that the device is still working (*still alive*).



Heartbeat (Periodic Alive Notification)

Period

Figure 3. Heartbeat (Periodical Alive Notification).

Note: *The first sending after download or bus failure takes place with a delay of up to 255 seconds, to prevent bus overload. The following sendings match the period set.*

- **Device Recovery Objects (Send 0 and 1)** [[disabled/enabled](#)]: this parameter lets the integrator activate two new communication objects (“**[Heartbeat] Device Recovery**”), which will be sent to the KNX bus with values “0” and “1” whenever the device begins operation (for example, after a bus power failure). It is possible to parameterise a certain **delay** [[0...255](#)][s] to this sending.

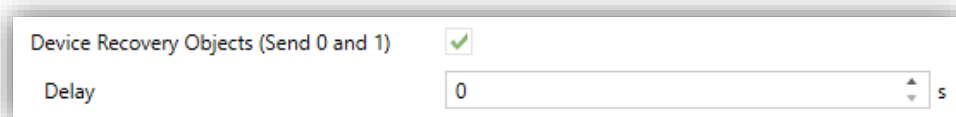

Device Recovery Objects (Send 0 and 1)

Delay s

Figure 4. Device Recovery Objects.

Note: *After download or bus failure, the sending takes place with a delay of up to 6,35 seconds plus the parameterised delay, to prevent bus overload.*

- **Scene after Download** [Configured by Parameters/Keep Saved Scenes]: allows defining whether the value of the scenes is the configured by parameter or whether the previously saved value is kept after download.

Note: if “Keep Saved Scenes” option has been configured, but it is the first download of the device or a different version from the current one, the values configured by parameter will be adopted. If new scenes are added in successive downloads, it will be necessary to perform a download by checking the option “Configured by Parameters” to ensure the correct operation of these scenes.

- **Manual Control** [disabled/enabled]: enables or disables the “Manual Control” tab on the left menu. See section 2.7 for more details.

2.2 ANALOG INPUT

The MINIBOX 0-10V X3/X2/X1 devices incorporate **three/two/one analog inputs** which can be used to connect different sensors with different **voltage** (0-10V, 0-1V y 1-10V) or **current** (0-20mA y 4-20mA) measurement ranges.

Please refer to the specific user manual “**Analog Inputs**”, available in the MINIBOX 0-10V product sections, at the Zennio website (www.zennio.com) for detailed information about the functionality and the configuration of the related parameters.

2.3 ANALOG VOLTAGE OUTPUT

The MINiBOX 0-10V X3/X2/X1 devices incorporate **three/two/one 0-10V analog outputs** which can be used to control **fans** and **valves** of a fan coil unit or other adjustable loads that operate between these voltage levels, by the configuration of **generic outputs**.

Please refer to the specific user manual “**Analog Voltage Output**”, available in the MINiBOX 0-10V product sections, at the Zennio website (www.zennio.com) for detailed information about the functionality and the configuration of the related parameters.

2.3.1 OPERATING TIME COUNTER

When an analog output is enabled, it is possible to configure the **operating time counter**, a function that offers the possibility to record the time the output is on or off.

It is possible to select the **counting mode**, as well as reading and updating the counters values by directly acting over the enabled objects (for example, the user can reset the counters by writing the value 0 in any of the objects, which will update both objects at the same time).

ETS PARAMETERISATION

When the **Operating Time Counter** option is enabled on an analog voltage output type channel, a tab on the left menu appears, in which the following parameters are available:

Seconds	<input type="checkbox"/>
Hours	<input checked="" type="checkbox"/>
Counting Mode	<input type="radio"/> Output Off <input checked="" type="radio"/> Output On
Initial Operating Time	<input type="radio"/> Keep Value <input checked="" type="radio"/> Defined Value
Value	<input type="text" value="0"/>
	<input type="radio"/> s <input checked="" type="radio"/> h
Periodic Sending (0 = Disabled)	<input type="text" value="0"/>
	<input type="text" value="h"/>

Figure 5. Operating Time Counter.

- **Seconds** [[disabled/enabled](#)]: enables or disables the object “[AOx] Operating Time (s)”, corresponding to the counter record (in seconds) of the time that the output remains switched on/off. The maximum value is 235926000 (when the maximum limit is reached, this value is maintained).
- **Hours** [[disabled/enabled](#)]: enables or disables the object “[AOx] Operating Time (h)”, corresponding to the counter record (in hours) of the time that the output remains switched on/off. The maximum value is 65535 (when the maximum limit is reached, this value is maintained).
- **Counting Mode** [[Output Off / Output On](#)]: sets whether the counter will save the time the output remains on or the time the output remains off.
- **Initial Operating Time** [[Keep Value / Defined Value](#)]: defines the initial value after download. When selecting “[Defined Value](#)” the following parameter will be displayed:
 - **Value** [[0...65535](#)][[s/h](#)]: sets de initial value after download.
- **Periodic Sending (0 = Disabled)** [[0...65535](#)][[s/min/h](#)]: sets a periodic sending for the enabled objects (“[AOx] Operating Time (s)” and/or “[AOx] Operating Time (h)”).

2.4 FAN COIL

The MINiBOX 0-10V X3/X2/X1 devices incorporate **three/two/one** modules to control the **fan** and **valves** of a **2 or 4 pipes** fan coil unit.

Please refer to the specific user manual “**Fan Coil ‘Analog’**”, available in the MINiBOX 0-10V product sections, at the Zennio website (www.zennio.com) for detailed information about the functionality and the configuration of the related parameters.

2.5 THERMOSTATS

The MINIBOX 0-10V X3/X2/X1 incorporate **three/two/one Zennio thermostats** that can be enabled and configured independently.

Please refer to the specific “**Zennio Thermostat**” user manual (available in the MINIBOX 0-10V product sections at the Zennio website, www.zennio.com) for detailed information about the functionality and the configuration of the related parameters.

2.6 LOGIC FUNCTIONS

This module makes it possible to perform numeric and binary operations to incoming values received from the KNX bus, and to send the results through other communication objects specifically enabled for this purpose.

The MINiBOX 0-10V devices can implement **up to 10 different and independent functions**, each of them entirely customisable and consisting of **up to 4 consecutive operations each**.

The execution of each function can depend on a configurable **condition**, which will be evaluated every time the function is **triggered** through specific, parameterizable communication objects. The result after executing the operations of the function can also be evaluated according to certain **conditions** and afterwards sent (or not) to the KNX bus, which can be done every time the function is executed, periodically or only when the result differs from the last one.

Please refer to the specific “**Logic Functions**” user manual (available in the MINiBOX 0-10V product sections at the Zennio homepage, www.zennio.com) for detailed information about the functionality and the configuration of the related parameters.

2.7 MANUAL CONTROL

The MINIBOX 0-10V devices, include manual control of its outputs through the respective pushbuttons on the top of the device. Therefore, a specific pushbutton is available per output.

Manual operation can be done in two different ways, named as **Test On Mode** (for testing purposes during the configuration of the device) and **Test Off Mode** (for a normal use, anytime). Whether both, only one, or none of these modes can be accessed needs to be parameterised in ETS. Moreover, it is possible to enable a specific binary object for locking and unlocking the manual control in runtime.

Notes:

- *The **Test Off mode** will be active (unless it has been disabled by parameter) after a download or a reset with no need of a specific activation – the pushbuttons will respond to user presses from the beginning.*
- *On the contrary, switching to the **Test On mode** (unless disabled by parameter) needs to be done by long-pressing the Prog./Test button (for at least three seconds), until the LED is no longer red and turns yellow. From that moment, once the button is released, the LED light will remain green to confirm that the device has switched from the Test Off mode to the Test On mode. After that, an additional press will turn the LED yellow and then off, once the button is released. This way, the device leaves the Test On mode. Note that the device will also leave this mode if a bus power failure takes place or if a manual control lock is sending from KNX bus.*

Test Off Mode

Under the Test Off Mode, the outputs can be controlled through both their communication objects and the actual pushbuttons located on the top of the device.

When one of these buttons is pressed, the output will behave as if an order had been received through the corresponding communication object.

- **Individual voltage output:** only the analog outputs configured as "**generic outputs**" can be controlled manually.

When the button is pressed, the device will act over the output according to the duration of the button press and to the current output state:

- **Short press:** action equivalent to a 0% or 100% control command in the output control object. The status is sent via the associated status object.
- **Long press:** initiates an increasing regulation if the output actual status is 0%, or a decreasing regulation if it is 100%. For values between 0 and 100%, the regulation direction is switched with each long press. The status object will be sent to the bus after stopping the press or reaching the minimum or maximum value.

In Test Off mode, any press on the buttons of the **outputs disabled** by parameter will have **no effect**.

Test On Mode

After entering the Test On mode, it will only be possible to control the outputs through the on-board pushbuttons. Orders received through communication objects will be ignored, regardless of the channel or the output they are addressed to.

- **Individual output:** the action performed on the output by pressing the physical buttons will be the same as described in the Test Off mode except that the status objects will not be affected.

Note: *unlike in test off mode, in test on mode any type of output can be controlled, not only the generic ones.*

Under the Test On mode, short and long presses will cause the **same effect for disabled outputs** as for analog voltage outputs.

As described previously if the device is in Test On mode, any command sent from the KNX bus to the actuator will not affect the outputs and no status objects will be sent (only periodically timed objects such as Heartbeat or logic functions will continue to be sent to the bus) while Test ON mode is active.

Important: *the device is factory delivered with all the output channels configured as disabled outputs, and with both manual modes (Test Off and Test On) enabled.*

ETS PARAMETERISATION

The **Manual Control** (enable by default as explained in section 2.1) is configured from the “Configuration” sub tab itself under “Manual Control”.

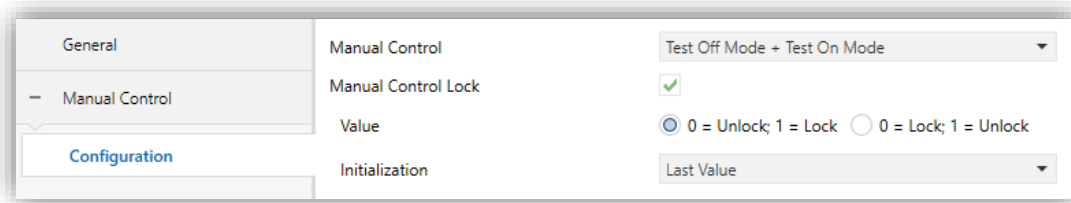

Figure 6. Manual control.

- **Manual Control** [*Disabled / Only Test Off Mode / Only Test On Mode / [Test Off Mode + Test On Mode](#)*]: Depending on the selection, the device will permit using the manual control under the Test Off, the Test On, or both modes. Note that, as stated before, using the Test Off mode does not require any special action, while switching to Test On mode does require long-pressing the Prog./Test button.
- **Lock Manual Control** [*disabled / enabled*]: unless the above parameter has been “Disabled”, the Lock Manual Control parameter provides an optional procedure for locking the manual control in runtime. When this checkbox is enabled, object “**Manual Control Lock**” turns visible, as well as two more parameters:
 - **Value** [*0 = Lock; 1 = Unlock / [0 = Unlock; 1 = Lock](#)*]: defines whether the manual control lock/unlock should take place upon the reception of values “0” and “1” respectively, or the opposite.
 - **Initialization** [*Unlocked / Locked / [Last Value](#)*]: sets how the lock manual control should be after the device start-up (after an ETS download or a bus power failure). The option “Last Value” will correspond to Unlocked on the first start-up.

ANNEX I. COMMUNICATION OBJECTS

- “**Functional range**” shows the values that, regardless of any other values permitted by the bus, given the object size, may be of useful or have a particular meaning because of the specifications or restrictions from the KNX standard or the application program itself.

Number	Size	I/O	Flags	Data type (DPT)	Functional Range	Name	Function
1	1 Bit		C--T-	DPT_Trigger	0/1	[Heartbeat] Object to Send '1'	Sending of '1' Periodically
2	1 Bit		C--T-	DPT_Trigger	0/1	[Heartbeat] Device Recovery	Send 0
3	1 Bit		C--T-	DPT_Trigger	0/1	[Heartbeat] Device Recovery	Send 1
4	1 Bit	I/O	CRW--	DPT_Enable	0/1	Manual Control Lock	0 = Unlock; 1 = Lock
	1 Bit	I/O	CRW--	DPT_Enable	0/1	Manual Control Lock	0 = Lock; 1 = Unlock
5, 12, 19	1 Byte	O	CR-T-	DPT_Value_1_Ucount	0 - 255	[AIx] Measured Value	(1-Byte) Unsigned
	1 Byte	O	CR-T-	DPT_Value_1_Count	-128 - 127	[AIx] Measured Value	(1-Byte) Signed
	2 Bytes	O	CR-T-	DPT_Value_2_Ucount	0 - 65535	[AIx] Measured Value	(2-Byte) Unsigned
	2 Bytes	O	CR-T-	DPT_Value_2_Count	-32768 - 32767	[AIx] Measured Value	(2-Byte) Signed
	2 Bytes	O	CR-T-	9.xxx	-671088.64 - 670433.28	[AIx] Measured Value	(2-Byte) Float
	4 Bytes	O	CR-T-	14.xxx		[AIx] Measured Value	(4-Byte) Float
	1 Byte	O	CR-T-	DPT_Scaling	0% - 100%	[AIx] Measured Value	(1-Byte) Percentage
6, 13, 20	1 Bit	O	CR-T-	DPT_Alarm	0/1	[AIx] Lower Range Error	0 = No Alarm; 1 = Alarm
7, 14, 21	1 Bit	O	CR-T-	DPT_Alarm	0/1	[AIx] Upper Range Error	0 = No Alarm; 1 = Alarm
8, 15, 22	1 Bit	O	CR-T-	DPT_Alarm	0/1	[AIx] Lower Threshold	0 = No Alarm; 1 = Alarm
9, 16, 23	1 Byte	I	C-W--	DPT_Value_1_Ucount	0 - 255	[AIx] Lower Threshold Value	(1-Byte) Unsigned
	1 Byte	I	C-W--	DPT_Value_1_Count	-128 - 127	[AIx] Lower Threshold Value	(1-Byte) Signed
	2 Bytes	I	C-W--	DPT_Value_2_Ucount	0 - 65535	[AIx] Lower Threshold Value	(2-Byte) Unsigned
	2 Bytes	I	C-W--	DPT_Value_2_Count	-32768 - 32767	[AIx] Lower Threshold Value	(2-Byte) Signed
	2 Bytes	I	C-W--	9.xxx	-671088.64 - 670433.28	[AIx] Lower Threshold Value	(2-Byte) Float
	4 Bytes	I	C-W--	14.xxx		[AIx] Lower Threshold Value	(4-Byte) Float
	1 Byte	I	C-W--	DPT_Scaling	0% - 100%	[AIx] Lower Threshold Value	(1-Byte) Percentage
10, 17, 24	1 Bit	O	CR-T-	DPT_Alarm	0/1	[AIx] Upper Threshold	0 = No Alarm; 1 = Alarm
11, 18, 25	1 Byte	I	C-W--	DPT_Value_1_Ucount	0 - 255	[AIx] Upper Threshold Value	(1-Byte) Unsigned
	1 Byte	I	C-W--	DPT_Value_1_Count	-128 - 127	[AIx] Upper Threshold Value	(1-Byte) Signed
	2 Bytes	I	C-W--	DPT_Value_2_Ucount	0 - 65535	[AIx] Upper Threshold Value	(2-Byte) Unsigned

	2 Bytes	I	C - W - -	DPT_Value_2_Count	-32768 - 32767	[AIx] Upper Threshold Value	(2-Byte) Signed
	2 Bytes	I	C - W - -	9.xxx	-671088.64 - 670433.28	[AIx] Upper Threshold Value	(2-Byte) Float
	4 Bytes	I	C - W - -	14.xxx		[AIx] Upper Threshold Value	(4-Byte) Float
	1 Byte	I	C - W - -	DPT_Scaling	0% - 100%	[AIx] Upper Threshold Value	(1-Byte) Percentage
26, 41, 56	1 Bit	I	C - W - -	DPT_Switch	0/1	[AOx] On/Off	0 = Off; 1 = On
27, 42, 57	1 Bit	O	CR - T -	DPT_Switch	0/1	[AOx] On/Off (Status)	0 = Off; 1 = On
28, 43, 58	4 Bit	I	C - W - -	DPT_Control_Dimming	0x0 (Stop) 0x1 (Dec. by 100%) ... 0x7 (Dec. by 1%) 0x8 (Stop) 0xD (Inc. by 100%) ... 0xF (Inc. by 1%)	[AOx] Relative Control	4-bits dimmer control
29, 44, 59	1 Byte	I	C - W T U	DPT_Scaling	0% - 100%	[AOx] Absolute Control	0 - 100 %
30, 45, 60	1 Byte	O	CR - T -	DPT_Scaling	0% - 100%	[AOx] Output (Status)	0 - 100 %
31, 46, 61	1 Bit	I	C - W - -	DPT_Switch	0/1	[AOx] Custom On/Off	0 = Off; 1 = On
32, 47, 62	1 Bit	I	C - W - -	DPT_DayNight	0/1	[AOx] Day/Night Mode	0 = Day Mode; 1 = Night Mode
	1 Bit	I	C - W - -	DPT_DayNight	0/1	[AOx] Day/Night Mode	0 = Night Mode; 1 = Day Mode
33, 48, 63	1 Bit	I	C - W - -	DPT_Switch	0/1	[AOx] Day/Night Mode On/Off	0 = Off; 1 = On
34, 49, 64	1 Bit	I	C - W - -	DPT_Start	0/1	[AOx] Simple Timer	0 = Deactivate; 1 = Activate
35, 50, 65	1 Bit	I	C - W - -	DPT_Start	0/1	[AOx] Flashing	0 = Deactivate; 1 = Activate
36, 51, 66	1 Bit	I	C - W T U	DPT_Enable	0/1	[AOx] Lock	0 = Unlock; 1 = Lock
	1 Bit	I	C - W T U	DPT_Enable	0/1	[AOx] Lock	0 = Lock; 1 = Unlock
37, 52, 67	1 Bit	I	C - W - -	DPT_Alarm	0/1	[AOx] Alarm	0 = No Alarm; 1 = Alarm
	1 Bit	I	C - W - -	DPT_Alarm	0/1	[AOx] Alarm	0 = Alarm; 1 = No Alarm
38, 53, 68	1 Bit	I	C - W - -	DPT_Ack	0/1	[AOx] Unfreeze Alarm	Alarm = 0 + Unfreeze = 1 => End Alarm
	1 Bit	I	C - W - -	DPT_Ack	0/1	[AOx] Unfreeze Alarm	Alarm = 1 + Unfreeze = 1 => End Alarm
39, 54, 69	1 Bit	O	CR - T -	DPT_Switch	0/1	[AOx] Standby (status)	0 = Standby Off; 1 = Standby On
	1 Bit	O	CR - T -	DPT_Switch	0/1	[AOx] Standby (status)	0 = Standby On; 1 = Standby Off
40, 55, 70	1 Byte	I	C - W - -	DPT_SceneControl	0-63; 128-191	[AOx] Scenes	0 - 63 (Execute 1 - 64); 128 - 191 (Save 1 - 64)
71, 104, 137	1 Bit	I	C - W T U	DPT_Switch	0/1	[FCx] On/Off	0 = Off; 1 = On
72, 105, 138	1 Bit	O	CR - T -	DPT_Switch	0/1	[FCx] On/Off (Status)	0 = Off; 1 = On
73, 106, 139	1 Bit	I	C - W T U	DPT_Heat_Cool	0/1	[FCx] Mode	0 = Cool; 1 = Heat
74, 107, 140	1 Bit	O	CR - T -	DPT_Heat_Cool	0/1	[FCx] Mode (Status)	0 = Cool; 1 = Heat
75, 108, 141	1 Byte	I	C - W T U	DPT_Scaling	0% - 100%	[FCx] Control Variable (Cooling)	0 - 100%

76, 109, 142	1 Byte	I	C - W T U	DPT_Scaling	0% - 100%	[FCx] Control Variable (Heating)	0 - 100%
77, 110, 143	1 Byte	I	C - W - -	DPT_SceneControl	0-63; 128-191	[FCx] Scenes	0 - 63 (Execute 1 - 64); 128 - 191 (Save 1 - 64)
78, 111, 144	1 Bit	I	C - W T U	DPT_Switch	0/1	[FCx] Cooling Valve: Control Variable (1 Bit)	0 = Close Valve; 1 = Open Valve
79, 112, 145	1 Byte	O	C R - T -	DPT_Scaling	0% - 100%	[FCx] Cooling Valve: Control (1 Byte)	0 - 100%
	1 Byte	O	C R - T -	DPT_Scaling	0% - 100%	[FCx] Valve: Control (1 Byte)	0 - 100%
	1 Bit	O	C R - T -	DPT_OpenClose	0/1	[FCx] Cooling Valve: Control (1 Bit)	0 = Open; 1 = Closed
	1 Bit	O	C R - T -	DPT_OpenClose	0/1	[FCx] Valve: Control (1 Bit)	0 = Open; 1 = Closed
	1 Bit	O	C R - T -	DPT_Switch	0/1	[FCx] Cooling Valve: Control (1 Bit)	0 = Closed; 1 = Open
	1 Bit	O	C R - T -	DPT_Switch	0/1	[FCx] Valve: Control (1 Bit)	0 = Closed; 1 = Open
80, 113, 146	1 Bit	O	C R - T -	DPT_Switch	0/1	[FCx] Cooling Valve: Anti-Seize Protection (Status)	0 = Not Active; 1 = Active
	1 Bit	O	C R - T -	DPT_Switch	0/1	[FCx] Valve: Anti-Seize Protection (Status)	0 = Not Active; 1 = Active
81, 114, 147	1 Bit	I	C - W T U	DPT_Switch	0/1	[FCx] Heating Valve: Control Variable (1 Bit)	0 = Close Valve; 1 = Open Valve
82, 115, 148	1 Byte	O	C R - T -	DPT_Scaling	0% - 100%	[FCx] Heating Valve: Control (1 Byte)	0 - 100%
	1 Bit	O	C R - T -	DPT_OpenClose	0/1	[FCx] Heating Valve: Control (1 Bit)	0 = Open; 1 = Closed
	1 Bit	O	C R - T -	DPT_Switch	0/1	[FCx] Heating Valve: Control (1 Bit)	0 = Closed; 1 = Open
83, 116, 149	1 Bit	O	C R - T -	DPT_Switch	0/1	[FCx] Heating Valve: Anti-Seize Protection (Status)	0 = Not Active; 1 = Active
84, 117, 150	1 Bit	I	C - W T U	DPT_Enable	0/1	[FCx] Fan: Manual/Automatic	0 = Automatic; 1 = Manual
	1 Bit	I	C - W T U	DPT_Enable	0/1	[FCx] Fan: Manual/Automatic	0 = Manual; 1 = Automatic
85, 118, 151	1 Bit	O	C R - T -	DPT_Enable	0/1	[FCx] Fan: Manual/Automatic (Status)	0 = Automatic; 1 = Manual
	1 Bit	O	C R - T -	DPT_Enable	0/1	[FCx] Fan: Manual/Automatic (Status)	0 = Manual; 1 = Automatic
86, 119, 152	1 Byte	O	C R - T -	DPT_Scaling	0% - 100%	[FCx] Fan: Speed Control	0 - 100%
87, 120, 153	1 Bit	O	C R - T -	DPT_Switch	0/1	[FCx] Fan: Speed 1 Control	0 = Off; 1 = On
88, 121, 154	1 Bit	O	C R - T -	DPT_Switch	0/1	[FCx] Fan: Speed 2 Control	0 = Off; 1 = On
89, 122, 155	1 Bit	O	C R - T -	DPT_Switch	0/1	[FCx] Fan: Speed 3 Control	0 = Off; 1 = On
90, 123, 156	1 Bit	I	C - W T U	DPT_Switch	0/1	[FCx] Fan: Boost Mode	0 = Boost Mode Off; 1 = Boost Mode On

91, 124, 157	1 Bit	I	C - W T U	DPT_Step	0/1	[FCx] Manual Fan: Step Control	0 = Down; 1 = Up
92, 125, 158	1 Bit	I	C - W T U	DPT_Switch	0/1	[FCx] Manual Fan: Speed 0	0 = Off; 1 = On
93, 126, 159	1 Bit	I	C - W T U	DPT_Switch	0/1	[FCx] Manual Fan: Speed 1	0 = Off; 1 = On
94, 127, 160	1 Bit	I	C - W T U	DPT_Switch	0/1	[FCx] Manual Fan: Speed 2	0 = Off; 1 = On
95, 128, 161	1 Bit	I	C - W T U	DPT_Switch	0/1	[FCx] Manual Fan: Speed 3	0 = Off; 1 = On
96, 129, 162	1 Bit	I	C - W T U	DPT_Switch	0/1	[FCx] Manual Fan: Speed 4	0 = Off; 1 = On
97, 130, 163	1 Bit	I	C - W T U	DPT_Switch	0/1	[FCx] Manual Fan: Speed 5	0 = Off; 1 = On
98, 131, 164	1 Byte	I	C - W T U	DPT_Fan_Stage	0 - 255	[FCx] Manual Fan: Enumeration Control	S0 = 0; S1 = 20%; S2 = 40%; S3 = 60%; S4 = 80%; S5 = 100%
	1 Byte	I	C - W T U	DPT_Fan_Stage	0 - 255	[FCx] Manual Fan: Enumeration Control	S0 = 0; S1 = 50%; S2 = 100%
	1 Byte	I	C - W T U	DPT_Fan_Stage	0 - 255	[FCx] Manual Fan: Enumeration Control	S0 = 0; S1 = 33,3%; S2 = 66,6%; S3 = 100%;
	1 Byte	I	C - W T U	DPT_Fan_Stage	0 - 255	[FCx] Manual Fan: Enumeration Control	S0 = 0; S1 = 25%; S2 = 50%; S3 = 75%; S4 = 100%
	1 Byte	I	C - W T U	DPT_Fan_Stage	0 - 255	[FCx] Manual Fan: Enumeration Control	S0 = 0; S1 = 100%
99, 132, 165	1 Byte	I	C - W T U	DPT_Scaling	0% - 100%	[FCx] Manual Fan: Percentage Control	0 - 100%
100, 133, 166	2 Bytes	I	C - W T U	DPT_TimePeriodMin	0 - 65535	[FCx] Manual Fan: Manual Control Duration	0 = Endless; 1 - 1440 min
	2 Bytes	I	C - W T U	DPT_TimePeriodHrs	0 - 65535	[FCx] Manual Fan: Manual Control Duration	0 = Endless; 1 - 24 h
101, 134, 167	1 Byte	I	C - W T U	DPT_Scaling	0% - 100%	[FCx] Fan: Automatic Air Recirculation Speed	0 - 100%
	1 Byte	I	C - W T U	DPT_Fan_Stage	0 - 255	[FCx] Fan: Automatic Air Recirculation Speed	S0 = 0; S1 = 1; S2 = 2; S3 = 3
	1 Byte	I	C - W T U	DPT_Fan_Stage	0 - 255	[FCx] Fan: Automatic Air Recirculation Speed	S0 = 0; S1 = 1; S2 = 2
	1 Byte	I	C - W T U	DPT_Fan_Stage	0 - 255	[FCx] Fan: Automatic Air Recirculation Speed	S0 = 0; S1 = 1
102, 135, 168	1 Byte	O	C R - T -	DPT_Fan_Stage	0 - 255	[FCx] Fan: Speed Enumeration (Status)	S0 = 0; S1 = 1; S2 = 2; S3 = 3
	1 Byte	O	C R - T -	DPT_Fan_Stage	0 - 255	[FCx] Fan: Speed Enumeration (Status)	S0 = 0; S1 = 1; S2 = 2
	1 Byte	O	C R - T -	DPT_Fan_Stage	0 - 255	[FCx] Fan: Speed Enumeration (Status)	S0 = 0; S1 = 1
103, 136, 169	1 Byte	O	C R - T -	DPT_Scaling	0% - 100%	[FCx] Fan: Speed Percentage (Status)	0 - 100%
170	1 Byte	I	C - W - -	DPT_SceneControl	0-63; 128-191	[Thermostat] Scenes	Scene Value

171, 209, 247	2 Bytes	I	C - W T U	DPT_Value_Temp	-273.00° - 670433.28°	[Tx] Temperature Source 1	External Sensor Temperature
172, 210, 248	2 Bytes	I	C - W T U	DPT_Value_Temp	-273.00° - 670433.28°	[Tx] Temperature Source 2	External Sensor Temperature
173, 211, 249	2 Bytes	O	C R - T -	DPT_Value_Temp	-273.00° - 670433.28°	[Tx] Effective Temperature	Effective Control Temperature
174, 212, 250	1 Byte	I	C - W - -	DPT_HVACMode	1=Comfort 2=Standby 3=Economy 4=Building Protection	[Tx] Special Mode	1-Byte HVAC Mode
175, 213, 251	1 Bit	I	C - W - -	DPT_Ack	0/1	[Tx] Special Mode: Comfort	0 = Nothing; 1 = Trigger
	1 Bit	I	C - W - -	DPT_Switch	0/1	[Tx] Special Mode: Comfort	0 = Off; 1 = On
176, 214, 252	1 Bit	I	C - W - -	DPT_Ack	0/1	[Tx] Special Mode: Standby	0 = Nothing; 1 = Trigger
	1 Bit	I	C - W - -	DPT_Switch	0/1	[Tx] Special Mode: Standby	0 = Off; 1 = On
177, 215, 253	1 Bit	I	C - W - -	DPT_Ack	0/1	[Tx] Special Mode: Economy	0 = Nothing; 1 = Trigger
	1 Bit	I	C - W - -	DPT_Switch	0/1	[Tx] Special Mode: Economy	0 = Off; 1 = On
178, 216, 254	1 Bit	I	C - W - -	DPT_Ack	0/1	[Tx] Special Mode: Protection	0 = Nothing; 1 = Trigger
	1 Bit	I	C - W - -	DPT_Switch	0/1	[Tx] Special Mode: Protection	0 = Off; 1 = On
179, 217, 255	1 Bit	I	C - W - -	DPT_Window_Door	0/1	[Tx] Window Status (Input)	0 = Closed; 1 = Open
180, 218, 256	1 Bit	I	C - W - -	DPT_Trigger	0/1	[Tx] Comfort Prolongation	0 = Nothing; 1 = Timed Comfort
181, 219, 257	1 Byte	O	C R - T -	DPT_HVACMode	1=Comfort 2=Standby 3=Economy 4=Building Protection	[Tx] Special Mode Status	1-Byte HVAC Mode
182, 220, 258	2 Bytes	I	C - W - -	DPT_Value_Temp	-273.00° - 670433.28°	[Tx] Setpoint	Thermostat Setpoint Input
	2 Bytes	I	C - W - -	DPT_Value_Temp	-273.00° - 670433.28°	[Tx] Basic Setpoint	Reference Setpoint
183, 221, 259	1 Bit	I	C - W - -	DPT_Step	0/1	[Tx] Setpoint Step	0 = Decrease Setpoint; 1 = Increase Setpoint
184, 222, 260	2 Bytes	I	C - W - -	DPT_Value_Tempd	-671088.64° - 670433.28°	[Tx] Setpoint Offset	Float Offset Value
185, 223, 261	2 Bytes	O	C R - T -	DPT_Value_Temp	-273.00° - 670433.28°	[Tx] Setpoint Status	Current Setpoint
186, 224, 262	2 Bytes	O	C R - T -	DPT_Value_Temp	-273.00° - 670433.28°	[Tx] Basic Setpoint Status	Current Basic Setpoint
187, 225, 263	2 Bytes	O	C R - T -	DPT_Value_Tempd	-671088.64° - 670433.28°	[Tx] Setpoint Offset Status	Current Setpoint Offset
188, 226, 264	1 Bit	I	C - W - -	DPT_Reset	0/1	[Tx] Setpoint Reset	Reset Setpoint to Default
	1 Bit	I	C - W - -	DPT_Reset	0/1	[Tx] Offset Reset	Reset Offset
189, 227, 265	1 Bit	I	C - W - -	DPT_Heat_Cool	0/1	[Tx] Mode	0 = Cool; 1 = Heat
190, 228, 266	1 Bit	O	C R - T -	DPT_Heat_Cool	0/1	[Tx] Mode Status	0 = Cool; 1 = Heat
191, 229, 267	1 Bit	I	C - W - -	DPT_Switch	0/1	[Tx] On/Off	0 = Off; 1 = On
192, 230, 268	1 Bit	O	C R - T -	DPT_Switch	0/1	[Tx] On/Off Status	0 = Off; 1 = On
193, 231, 269	1 Bit	I/O	C R W - -	DPT_Switch	0/1	[Tx] Main System (Cool)	0 = System 1; 1 = System 2
194, 232, 270	1 Bit	I/O	C R W - -	DPT_Switch	0/1	[Tx] Main System (Heat)	0 = System 1; 1 = System 2

195, 233, 271	1 Bit	I	C - W - -	DPT_Enable	0/1	[Tx] Enable/Disable Secondary System (Cool)	0 = Disable; 1 = Enable
196, 234, 272	1 Bit	I	C - W - -	DPT_Enable	0/1	[Tx] Enable/Disable Secondary System (Heat)	0 = Disable; 1 = Enable
197, 203, 235, 241, 273, 279	1 Byte	O	CR - T -	DPT_Scaling	0% - 100%	[Tx] [Sx] Control Variable (Cool)	PI Control (Continuous)
198, 204, 236, 242, 274, 280	1 Byte	O	CR - T -	DPT_Scaling	0% - 100%	[Tx] [Sx] Control Variable (Heat)	PI Control (Continuous)
	1 Byte	O	CR - T -	DPT_Scaling	0% - 100%	[Tx] [Sx] Control Variable	PI Control (Continuous)
199, 205, 237, 243, 275, 281	1 Bit	O	CR - T -	DPT_Switch	0/1	[Tx] [Sx] Control Variable (Cool)	2-Point Control
	1 Bit	O	CR - T -	DPT_Switch	0/1	[Tx] [Sx] Control Variable (Cool)	PI Control (PWM)
200, 206, 238, 244, 276, 282	1 Bit	O	CR - T -	DPT_Switch	0/1	[Tx] [Sx] Control Variable (Heat)	2-Point Control
	1 Bit	O	CR - T -	DPT_Switch	0/1	[Tx] [Sx] Control Variable (Heat)	PI Control (PWM)
	1 Bit	O	CR - T -	DPT_Switch	0/1	[Tx] [Sx] Control Variable	2-Point Control
	1 Bit	O	CR - T -	DPT_Switch	0/1	[Tx] [Sx] Control Variable	PI Control (PWM)
201, 207, 239, 245, 277, 283	1 Bit	O	CR - T -	DPT_Switch	0/1	[Tx] [Sx] PI State (Cool)	0 = PI Signal 0%; 1 = PI Signal Greater than 0%
202, 208, 240, 246, 278, 284	1 Bit	O	CR - T -	DPT_Switch	0/1	[Tx] [Sx] PI State (Heat)	0 = PI Signal 0%; 1 = PI Signal Greater than 0%
	1 Bit	O	CR - T -	DPT_Switch	0/1	[Tx] [Sx] PI State	0 = PI Signal 0%; 1 = PI Signal Greater than 0%
285, 286, 287, 288, 289, 290, 291, 292, 293, 294, 295, 296, 297, 298, 299, 300, 301, 302, 303, 304, 305, 306, 307, 308, 309, 310, 311, 312, 313, 314, 315, 316	1 Bit	I	C - W - -	DPT_Bool	0/1	[LF] (1-Bit) Data Entry x	Binary Data Entry (0/1)
317, 318, 319, 320, 321, 322, 323, 324, 325, 326, 327, 328, 329, 330, 331, 332	1 Byte	I	C - W - -	DPT_Value_1_Ucount	0 - 255	[LF] (1-Byte) Data Entry x	1-Byte Data Entry (0-255)
333, 334, 335, 336, 337, 338, 339, 340, 341, 342, 343, 344, 345, 346, 347, 348	2 Bytes	I	C - W - -	DPT_Value_2_Ucount	0 - 65535	[LF] (2-Byte) Data Entry x	2-Byte Data Entry
349, 350, 351, 352, 353, 354, 355, 356	4 Bytes	I	C - W - -	DPT_Value_4_Count	-2147483648 - 2147483647	[LF] (4-Byte) Data Entry x	4-Byte Data Entry
357, 358, 359, 360, 361, 362, 363, 364, 365, 366	1 Bit	O	CR - T -	DPT_Bool	0/1	[LF] Function x - Result	(1-Bit) Boolean
	1 Byte	O	CR - T -	DPT_Value_1_Ucount	0 - 255	[LF] Function x - Result	(1-Byte) Unsigned
	2 Bytes	O	CR - T -	DPT_Value_2_Ucount	0 - 65535	[LF] Function x - Result	(2-Byte) Unsigned
	4 Bytes	O	CR - T -	DPT_Value_4_Count	-2147483648 - 2147483647	[LF] Function x - Result	(4-Byte) Signed
	1 Byte	O	CR - T -	DPT_Scaling	0% - 100%	[LF] Function x - Result	(1-Byte) Percentage
	2 Bytes	O	CR - T -	DPT_Value_2_Count	-32768 - 32767	[LF] Function x - Result	(2-Byte) Signed

	2 Bytes	O	CR-T-	9.xxx	-671088.64 - 670433.28	[LF] Function x - Result	(2-Byte) Float
367, 369, 371	4 Bytes	I/O	CRWT-	DPT_LongDeltaTimeSec	-2147483648 - 2147483647	[AOx] Operating Time (s)	Time in Seconds
368, 370, 372	2 Bytes	I/O	CRWT-	DPT_TimePeriodHrs	0 - 65535	[AOx] Operating Time (h)	Time in Hours



Join and send us your inquiries
about Zennio devices:
<https://support.zennio.com>

Zennio Avance y Tecnología S.L.
C/ Río Jarama, 132. Nave P-8.11
45007 Toledo (Spain).

Tel. +34 925 232 002.

www.zennio.com
info@zennio.com